

AXOR

AXOR

AXOR

POS GUIDELINES 2017

hansgrohe ShowTec

Brand CI POS - ShowTec

Showcase, inspire, sell: The introduction of ShowTec

Increase your success and visualize the brand through an attractive presentation of the Hansgrohe product range at the POS. The new Hansgrohe display system ShowTec provides the flexibility to allow adaptation of the layout to customer needs in terms of size, configuration, fittings and equipment, thanks to its modular construction.

Targets of ShowTec at a glance

- Fast placements of new products
- Flexible and modular system for easy updates
- High visibility of the brand
- Creation of a long term and attractive brand performance at the point of sale
- Attractive and cost efficient display system



Brand CI POS - ShowTec

1. NEWS display

Place the **latest product innovation** (e.g. Raindance Select) at an attractive price-performance ratio quickly in the showroom.



2. Brand Display

For a perfect presentation of **several product lines on one display** according to your requirements, designed to suit your customer's exhibition.

- Fast, customized displays with the whole Hansgrohe product assortment
- Variety of display sizes and geometries available according to the showroom requirements



Brand CI POS - ShowTec

3. Individual Display

Individual planning and compilation of product ranges and **several ShowTec display elements**, especially tailored to your customer's exhibition.

- Tailor-made to the showroom conditions and product requirements of your customers
- Comprehensive showroom



Brand CI POS - ShowTec

4. Miscellaneous Displays

The benefit of ShowTec is that it can be easily customised into various options to suit the needs of the showroom, yet maintaining a consistent brand image.

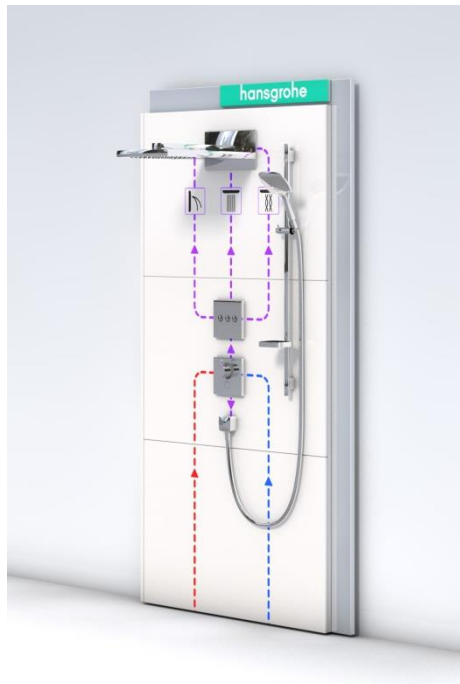

ShowTec Easy Install Display



ShowTec Product Range Display



ShowTec Store Display

ShowTec – as versatile as the showrooms

Which product category fits on which board combination?

Showerpipe / Shower Combi



Overhead Shower

Shower Set / Shower Mixer

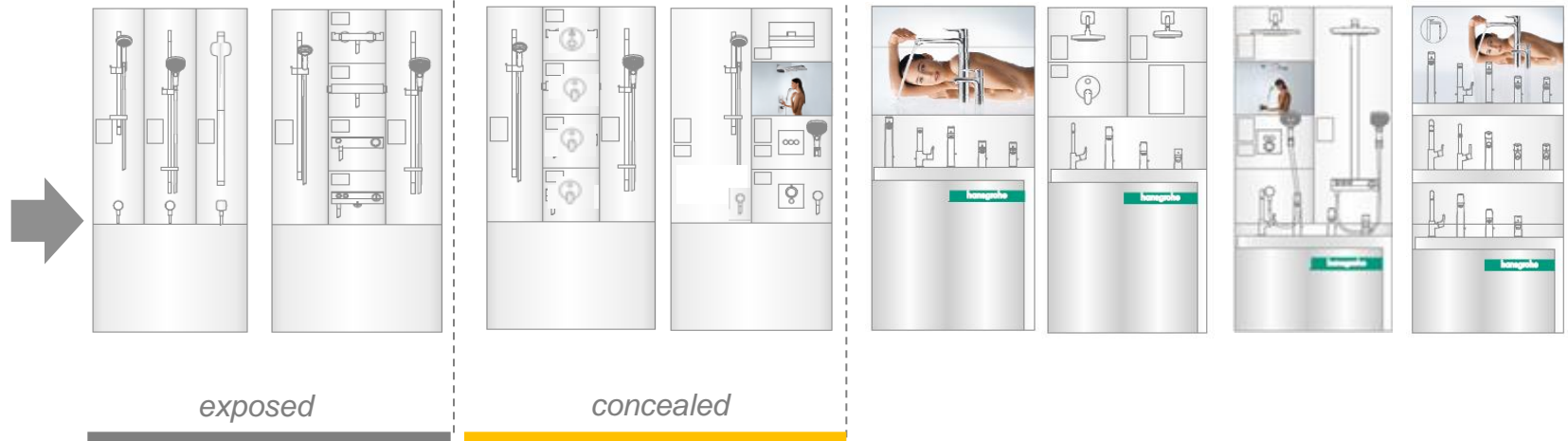

Basin Mixer

ShowTec – always the best solution

Customer experience with ShowTec



Panel Dimensions

Panel Sizes

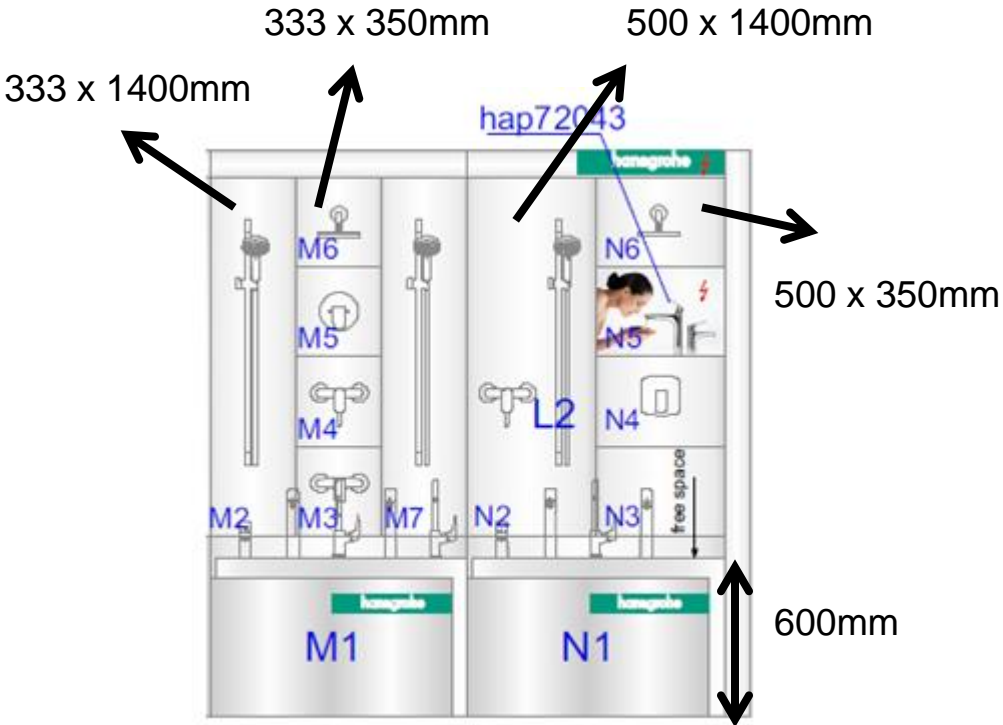
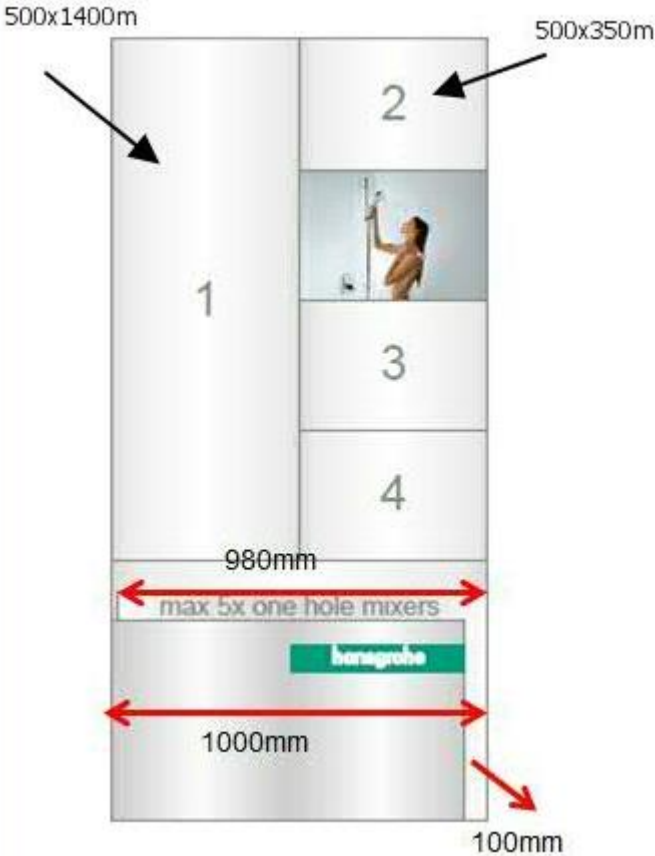

Example of dimensions

Panel Dimensions

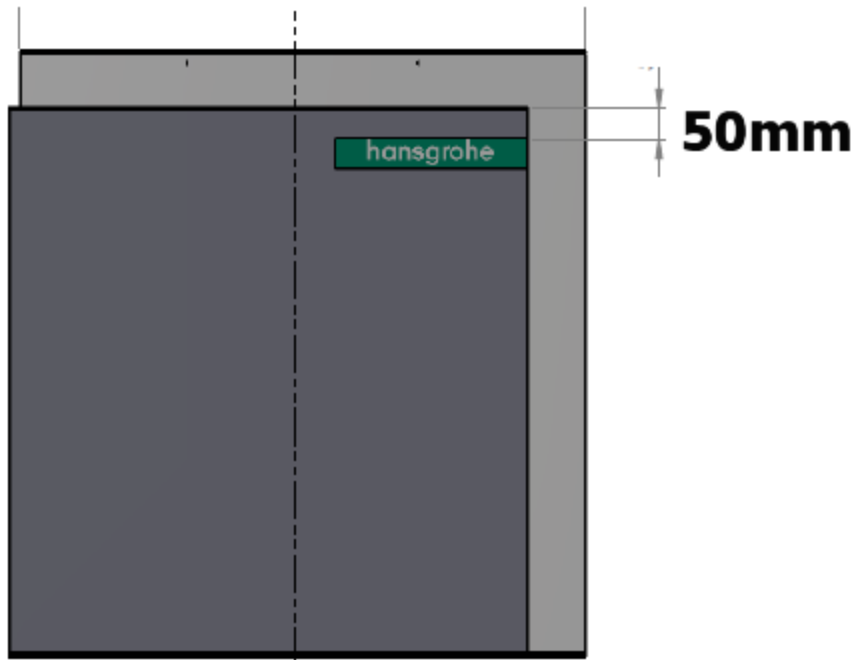

Product Positioning

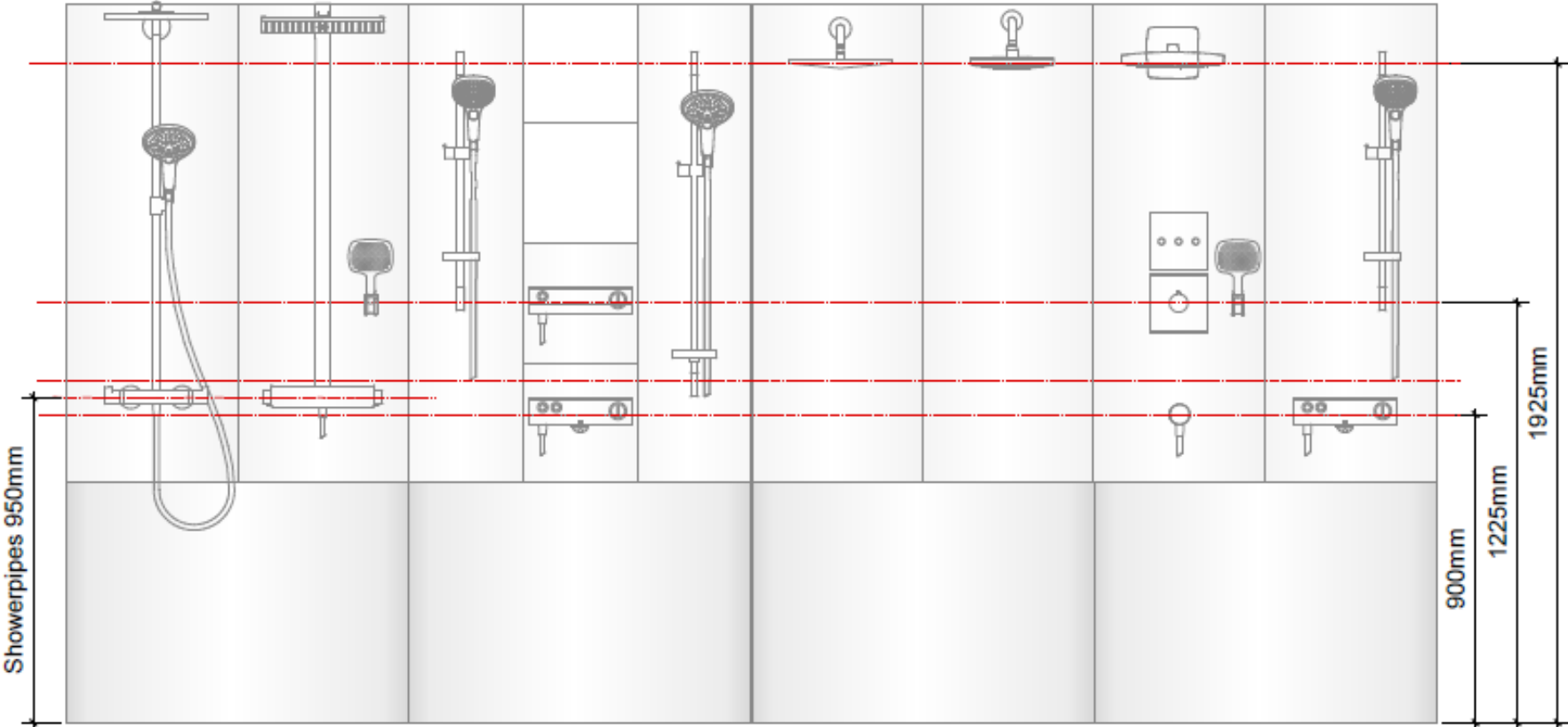

Chapter 2

Examples of hansgrohe Displays

ShowTec in SG Aquademie



Brand CI POS - ShowTec

Panel colour:

For best results (especially for flagship stores), use the following colors for the panels:

- White color: ESG 5709N Style White
- Silver color: EFL 2747G Ursula
- Black color: DYG 2409PG Classic Black

*Source: edleuro.com
(You may request for actual color sample from Hansgrohe)



hansgrohe Display Panels

hangrohe Display Panels

Modern Series



hangrohe Display Panels

Classic Series



hangrohe Display Panels

Avantgarde Series

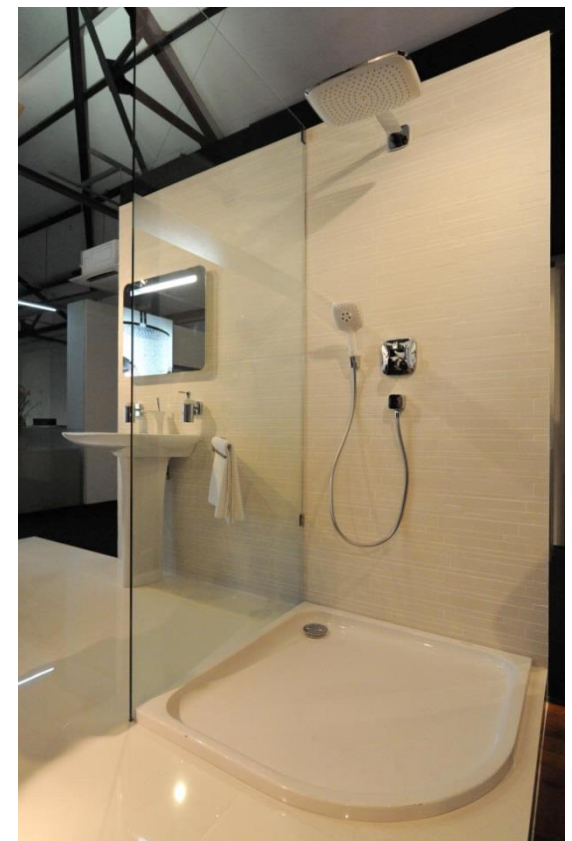

hangrohe Display Panels

Product Spacing:

- Products must be spaced apart comfortably in an aesthetical manner.
- For wall-mounted products, please refer to planogram on following page for an indicative guide.
- For top-lever basin mixers, spacing is typically 150mm, measured from centre to centre of mixer hole.
- For side-lever or 3-hole basin mixers, please allow spacing of around 100mm, measured from edge to edge of the mixers

Example:

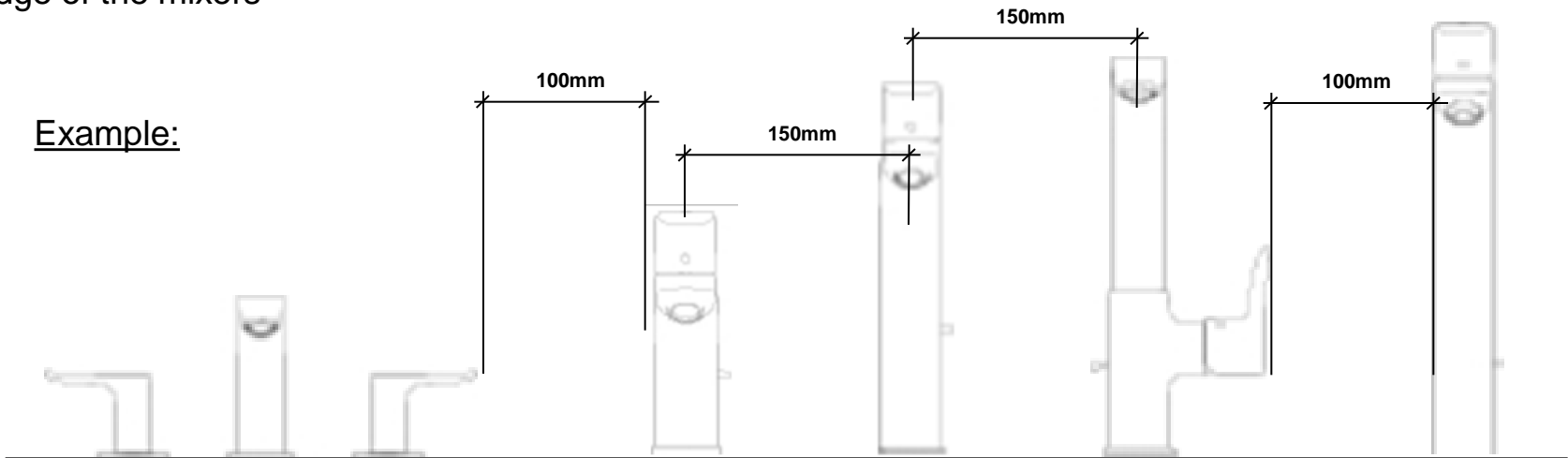

hangrohe Display Panels

Example

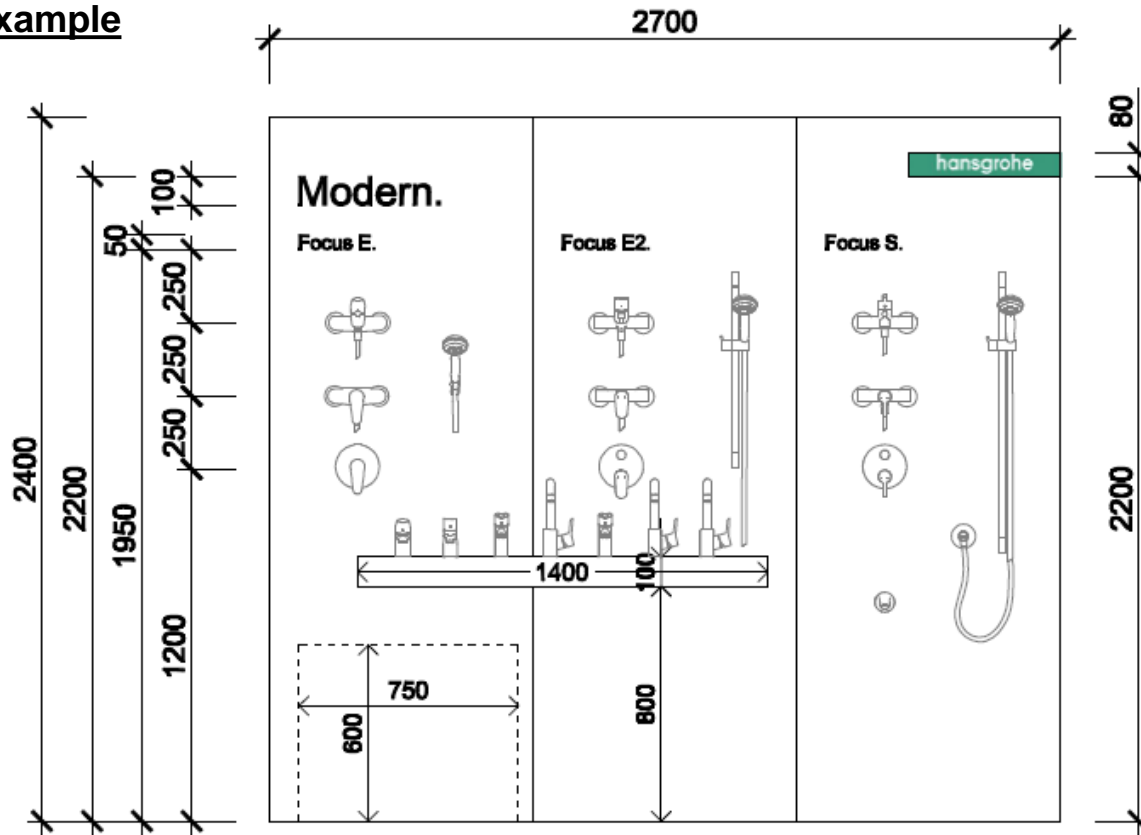

FRONT ELEVATION

SCALE 1:25

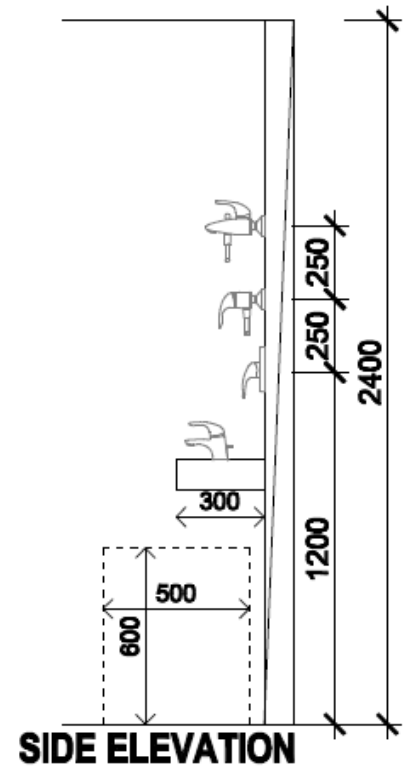

SIDE ELEVATION

hangrohe Display Panels

Example

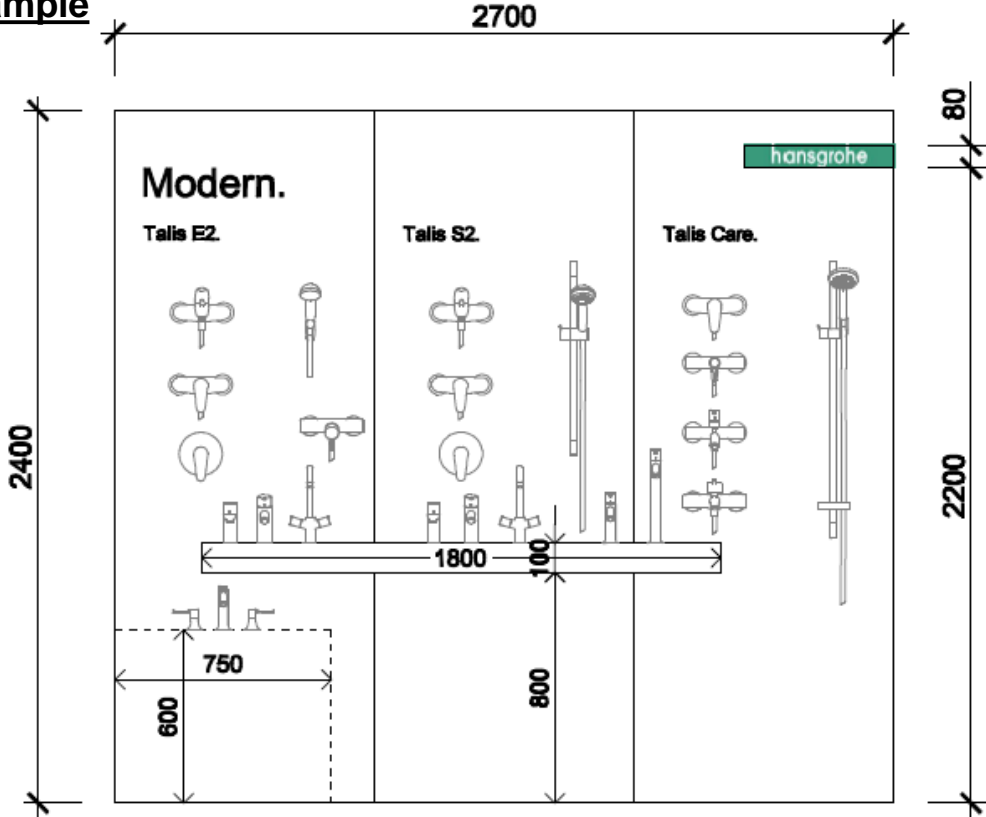

FRONT ELEVATION

SCALE 1:25

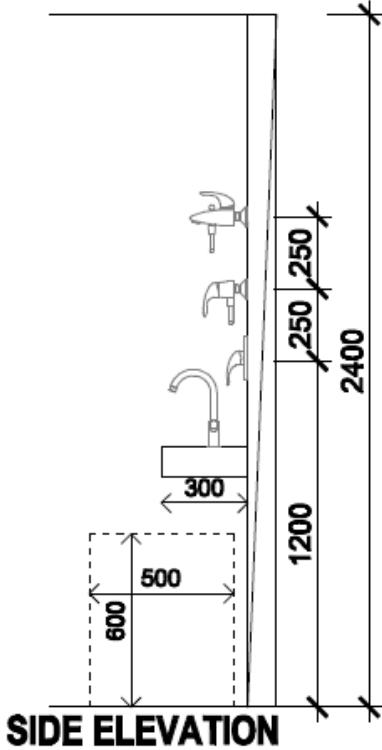

SIDE ELEVATION

hangrohe Display Panels

Example

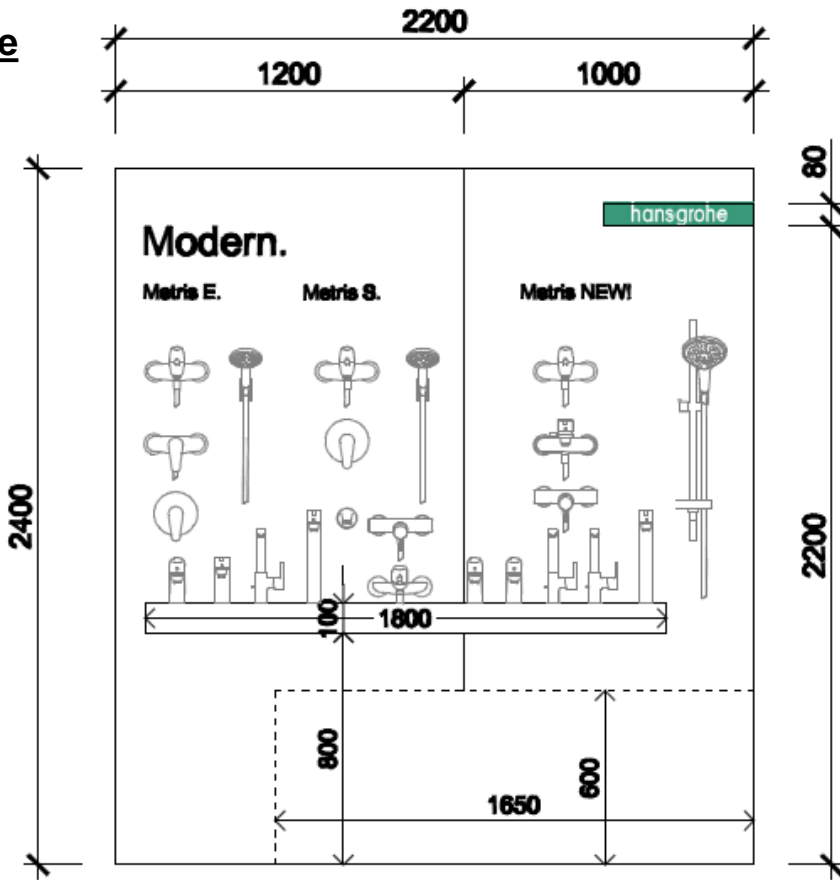

FRONT ELEVATION

SCALE 1:25

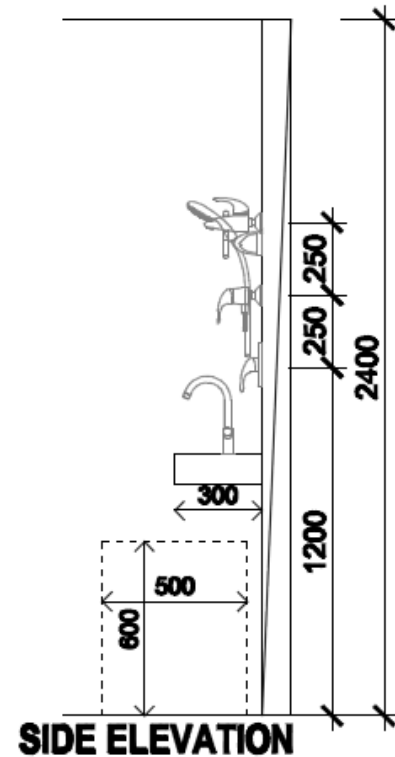

SIDE ELEVATION

hangrohe Display Panels

Example

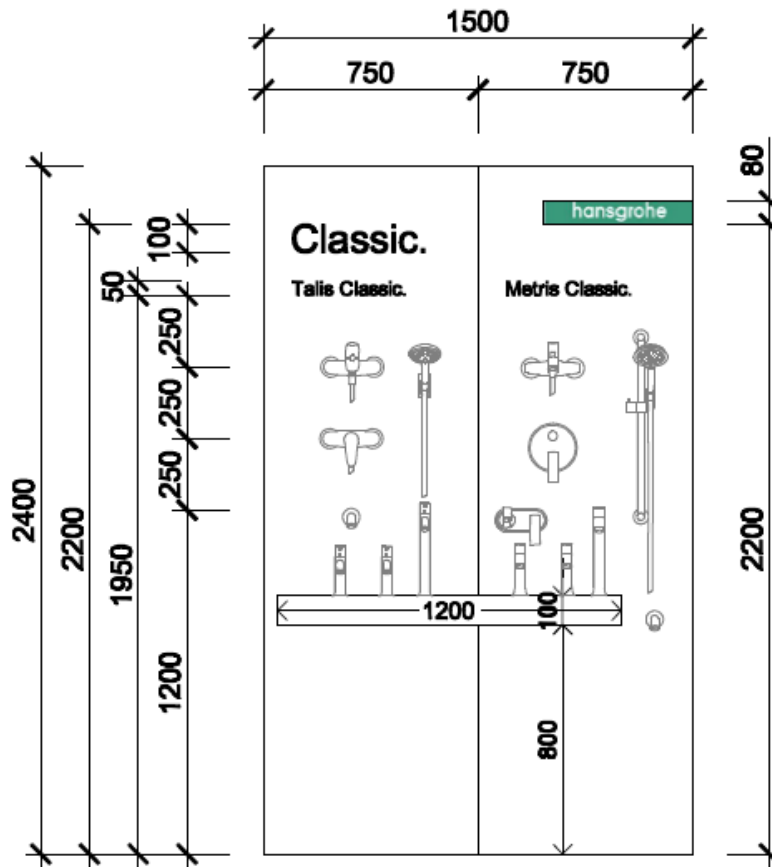

FRONT ELEVATION

SCALE 1:25

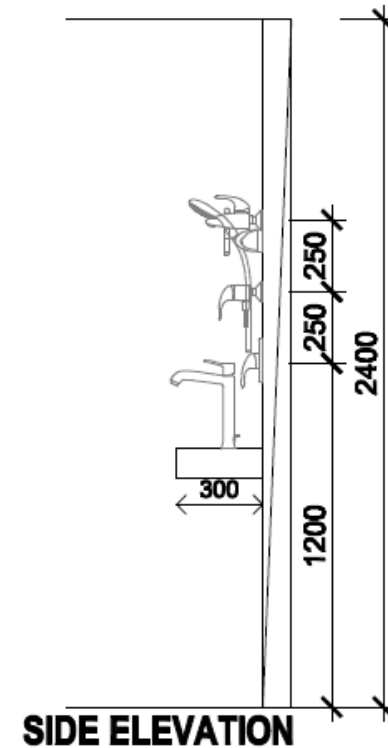

SIDE ELEVATION

hangrohe Display Panels

Example

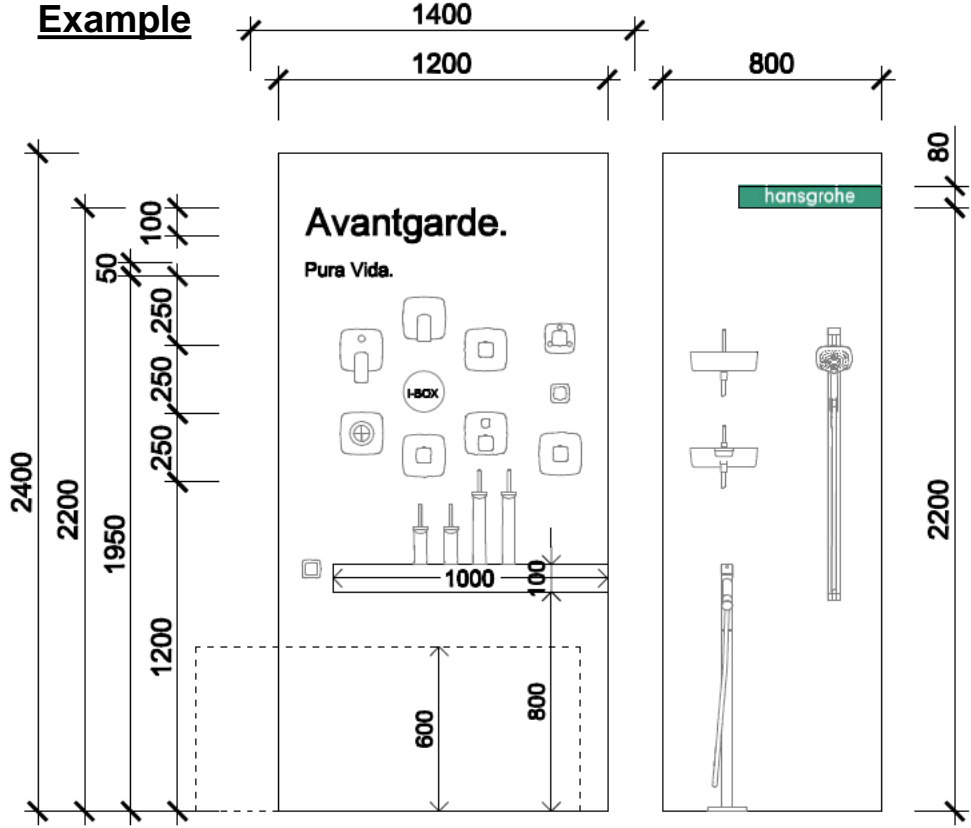

FRONT ELEVATION

SCALE 1:25

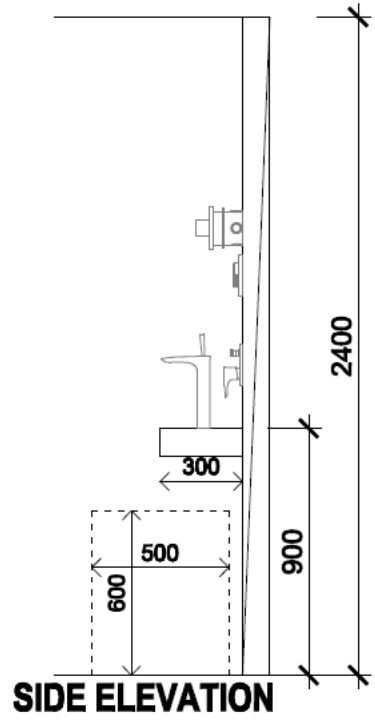

SIDE ELEVATION

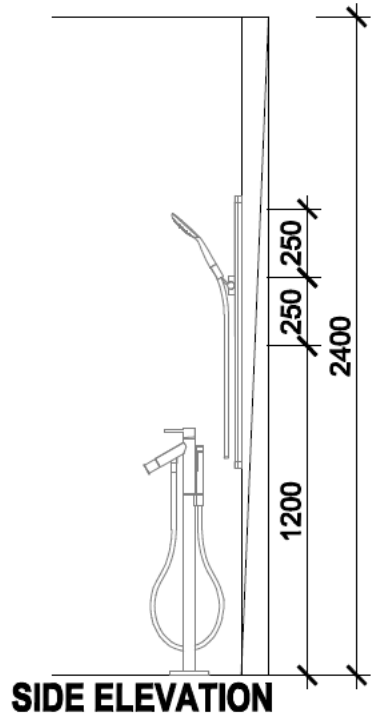

SIDE ELEVATION

hangrohe Display Panels

Showers Display Ideas:

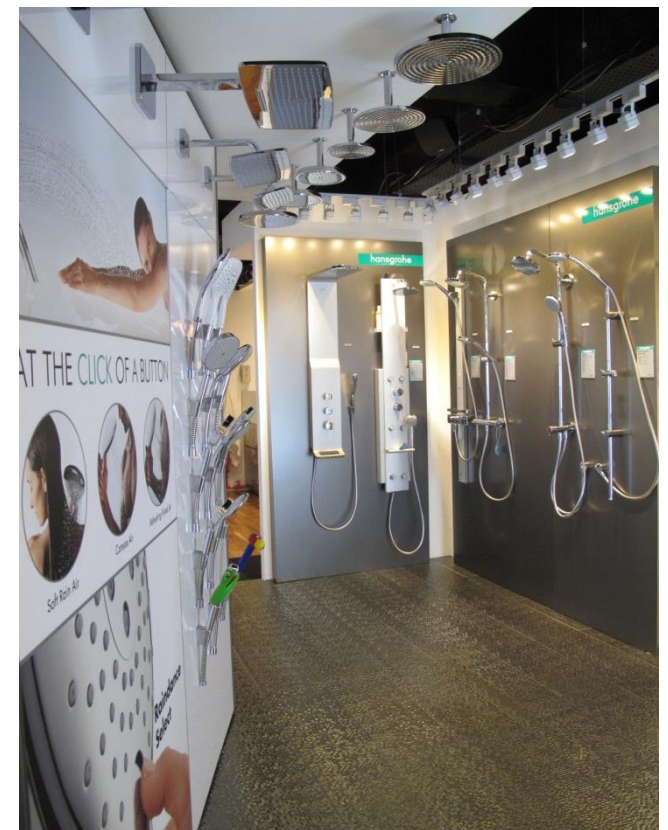

hangrohe Display Panels

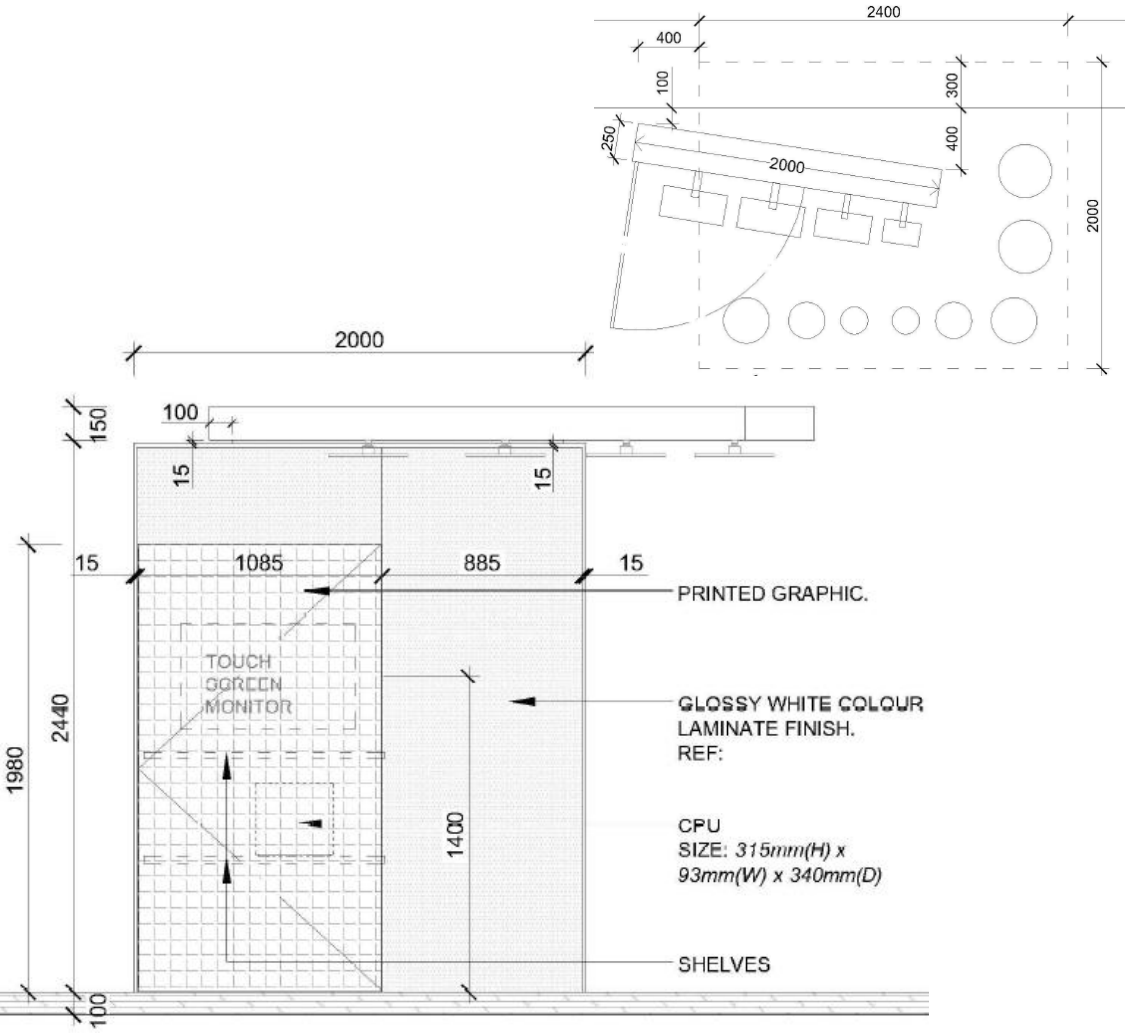

hangrohe Display Panels

Feature Wall for Touchscreen Programmes (Software provided by Hangrohe)

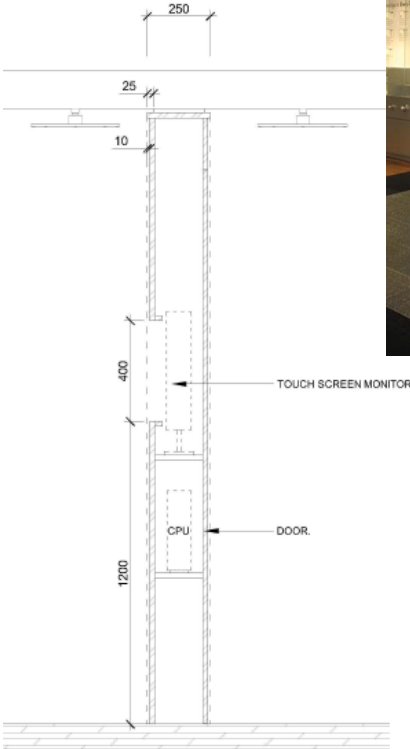
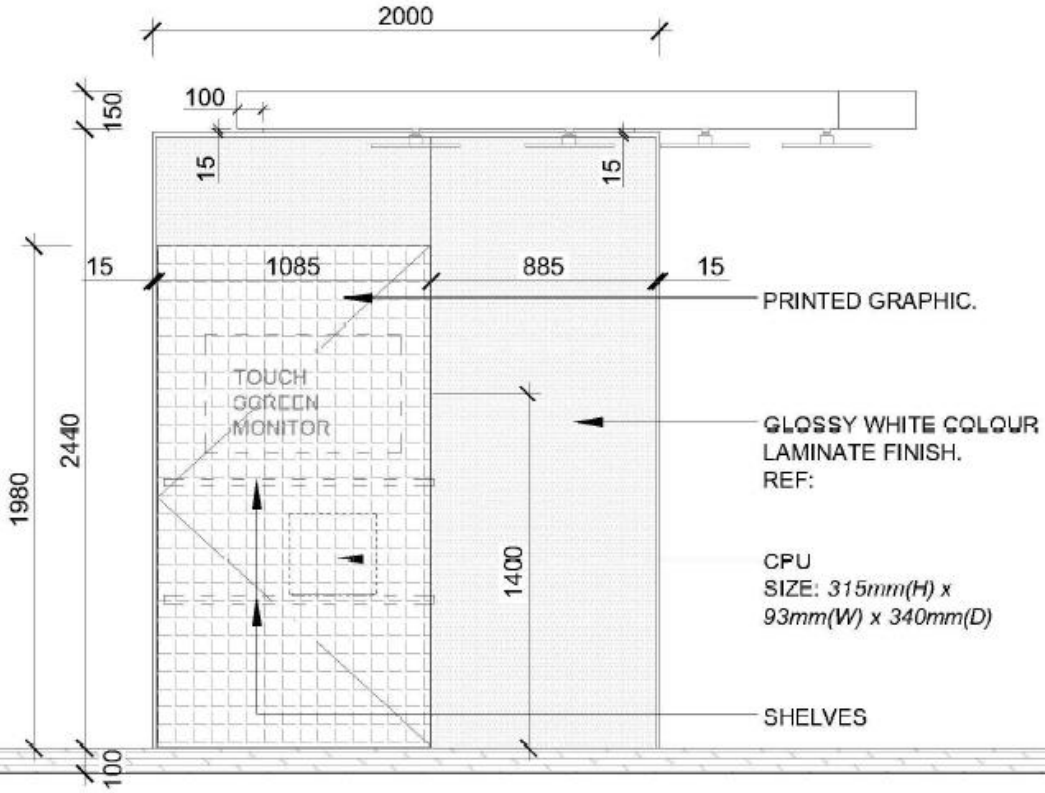

SECTIONAL VIEW



hangrohe Display Panels

Select Display Panels

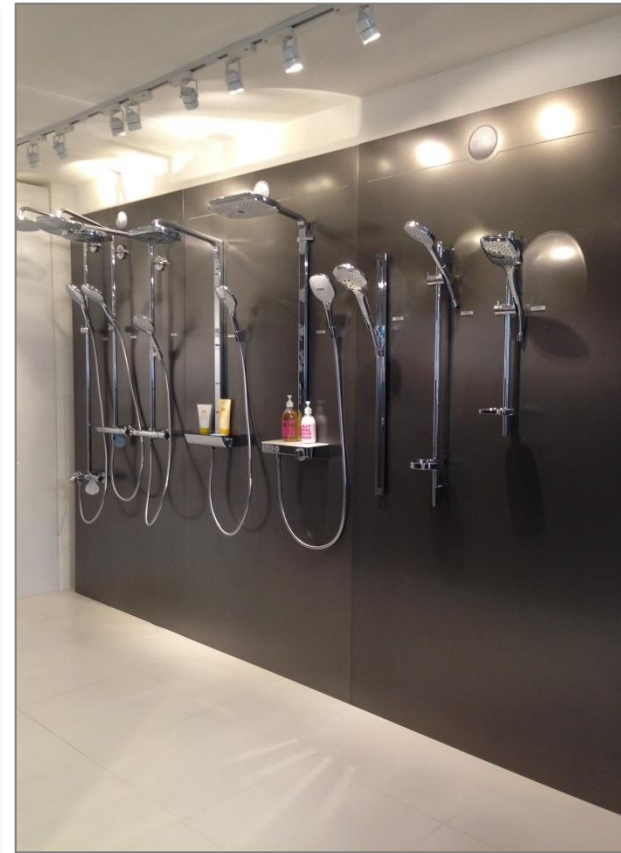

hangrohe Display Panels

Select Panels:

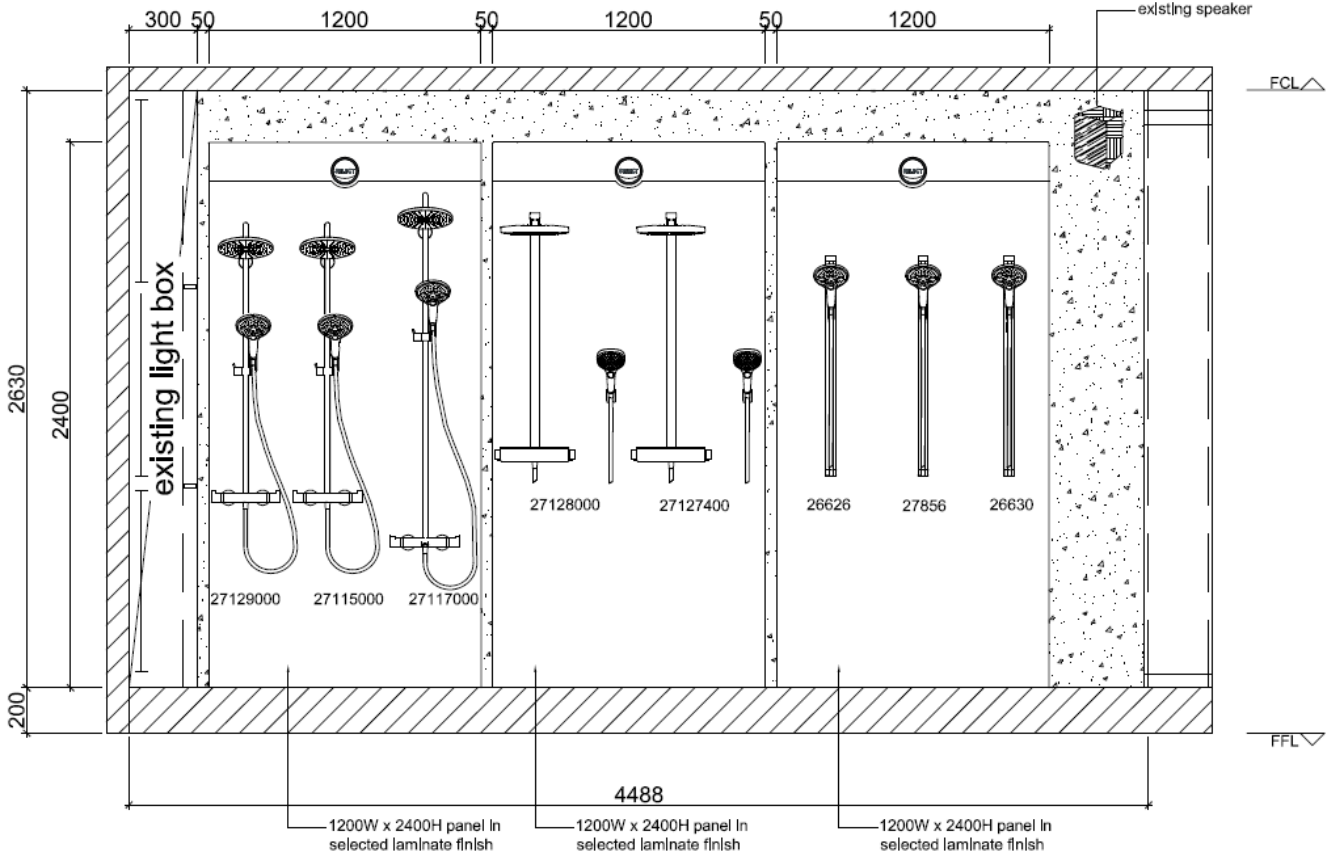

ELEVATION B
SCALE: 1:20

hangrohe Display Panels

Select Panels:

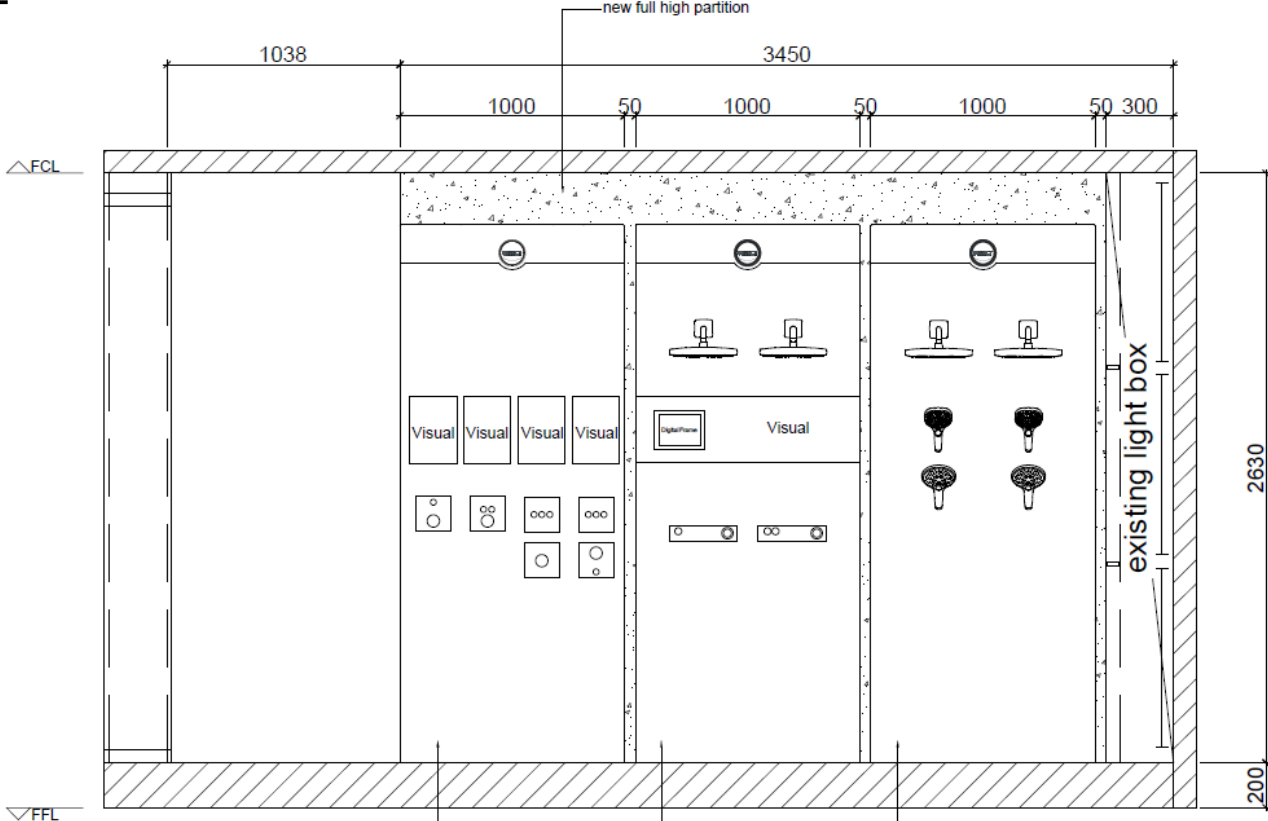

ELEVATION C
SCALE: 1:20

1000W x 2400H panel in selected laminate finish 1000W x 2400H panel in selected laminate finish 1000W x 2400H panel in selected laminate finish

hangrohe Bathroom Situations

Examples

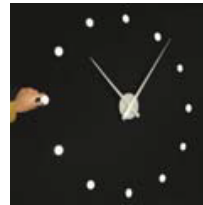

hangrohe Bathroom Situations



hangrohe Mini Bathroom Situations

Examples

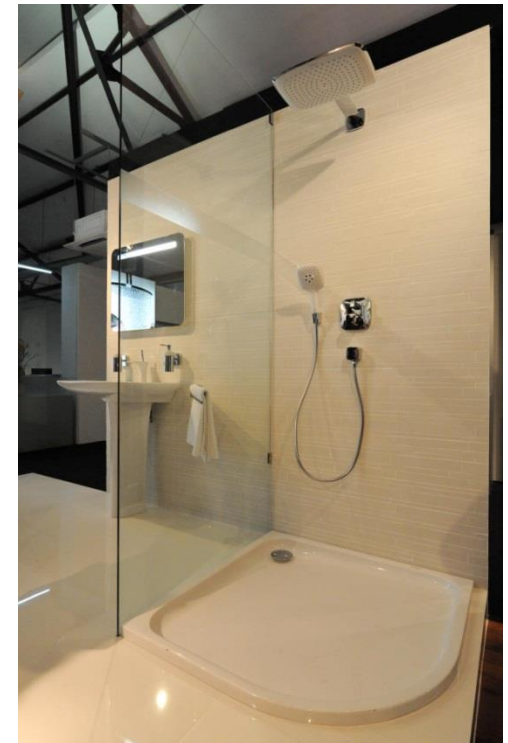

Kitchen Mixers Display

Examples



Kitchen Mixers Display

Examples

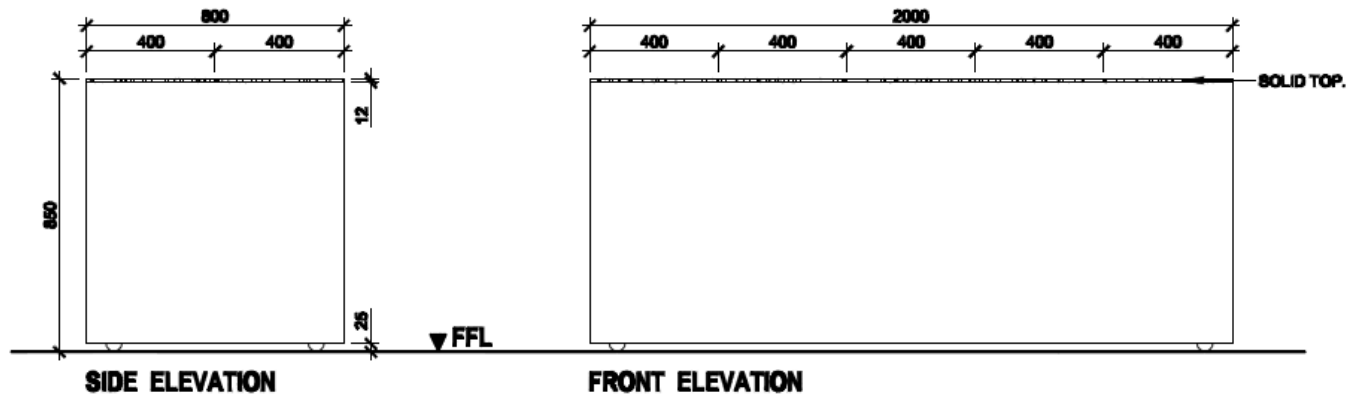
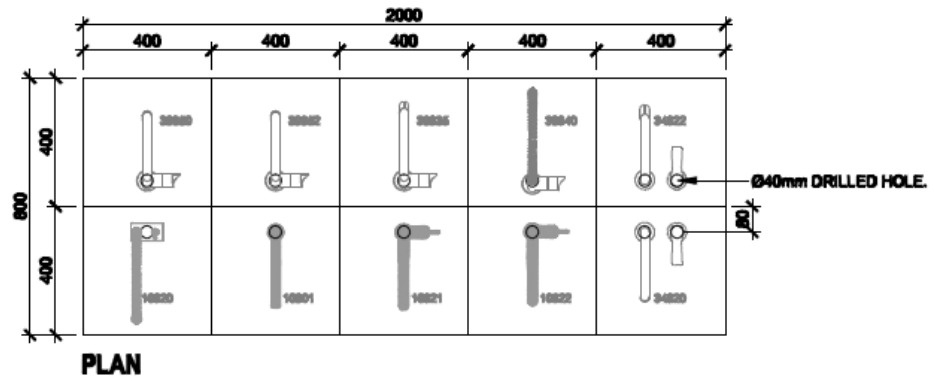

DISPLAY PEDESTAL FOR AXOR KITCHEN MIXERS

Kitchen Mixers Display

Examples

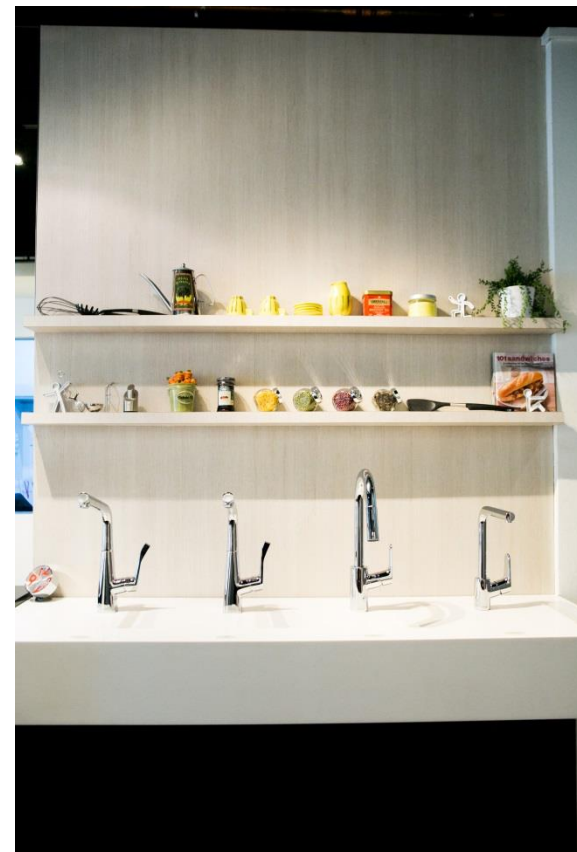

Kitchen Mixers Display

Examples

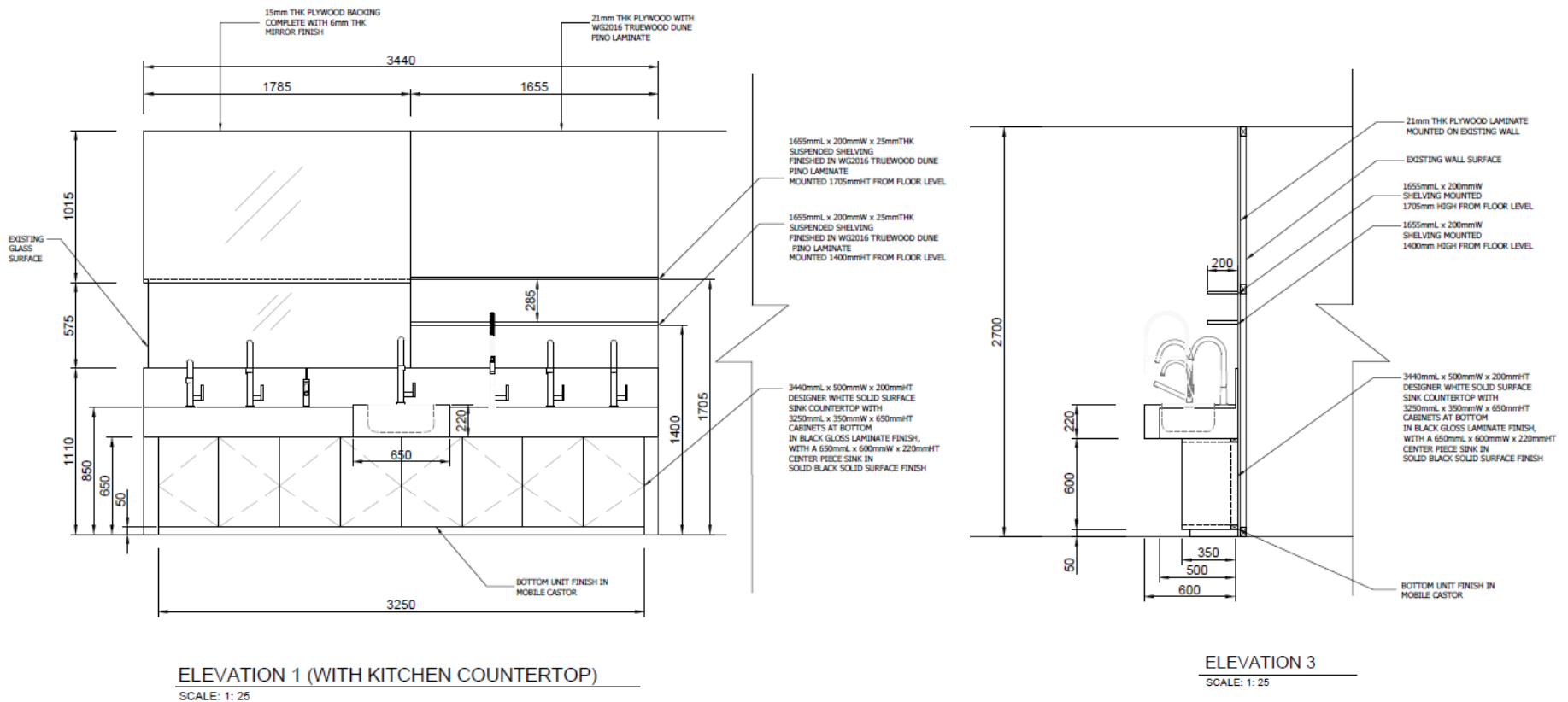

Kitchen Mixers Display

Examples



TOP VIEW

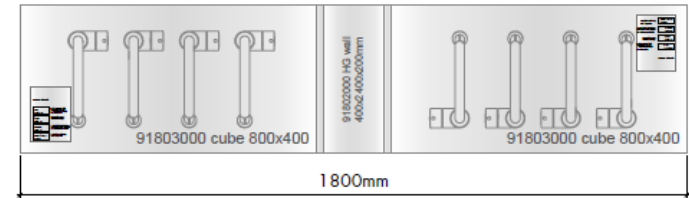

FRONT VIEW

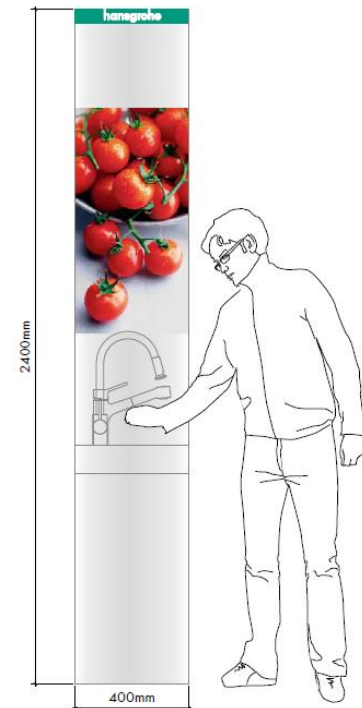

Customised Live Testing Area

Examples

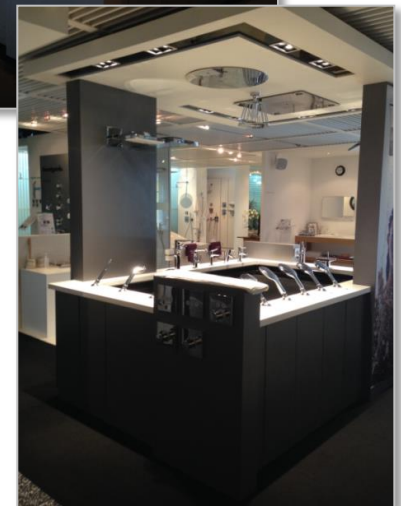
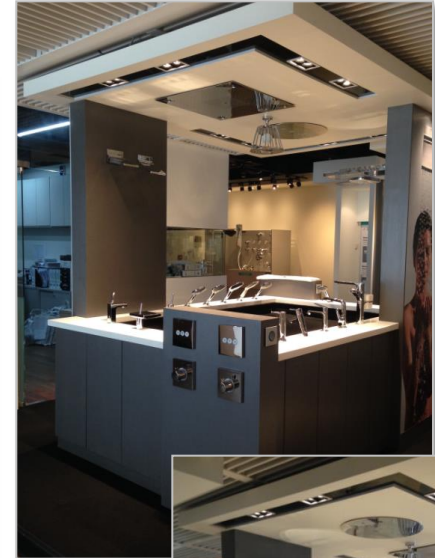

Customised Live Testing Area

Examples

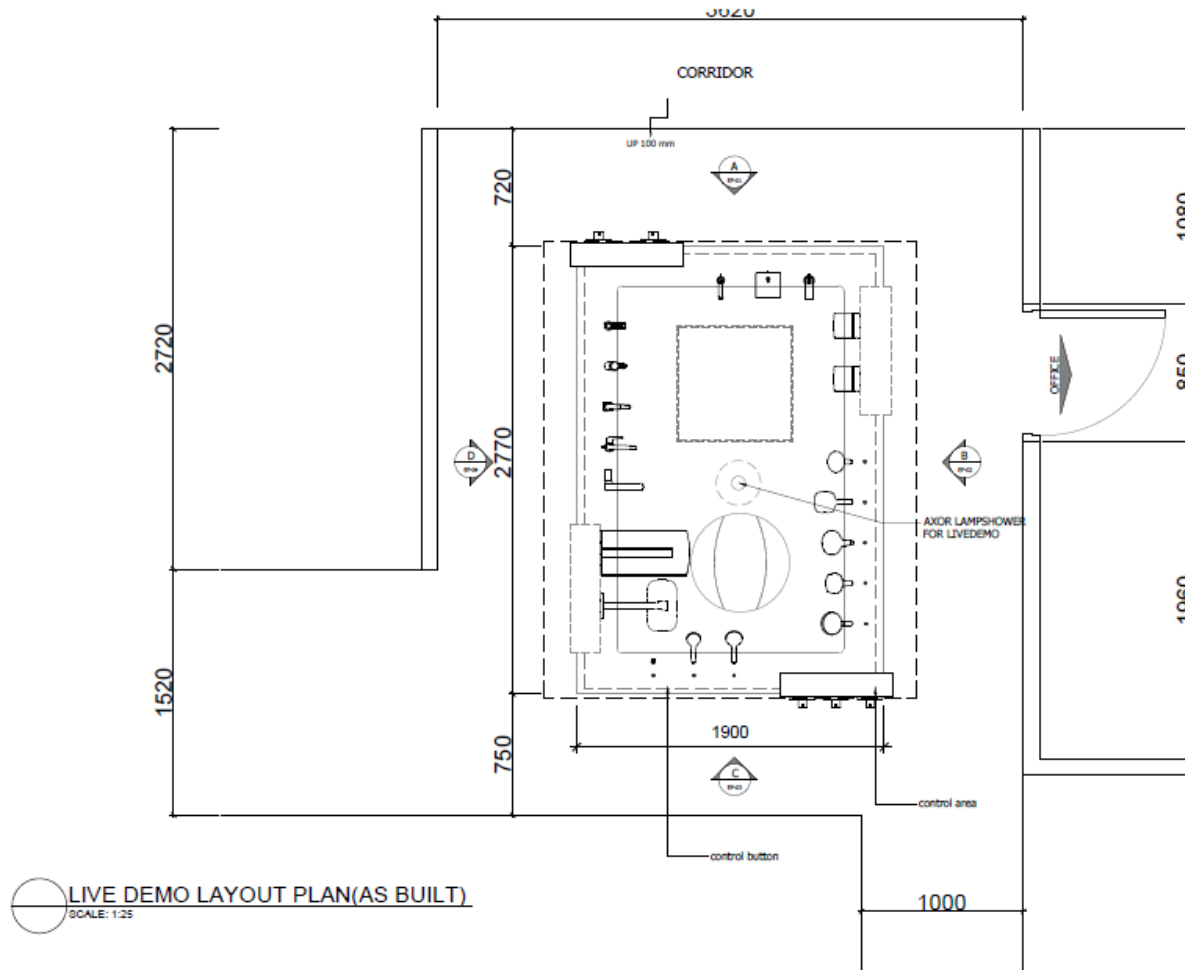

Customised Live Testing Area

Examples

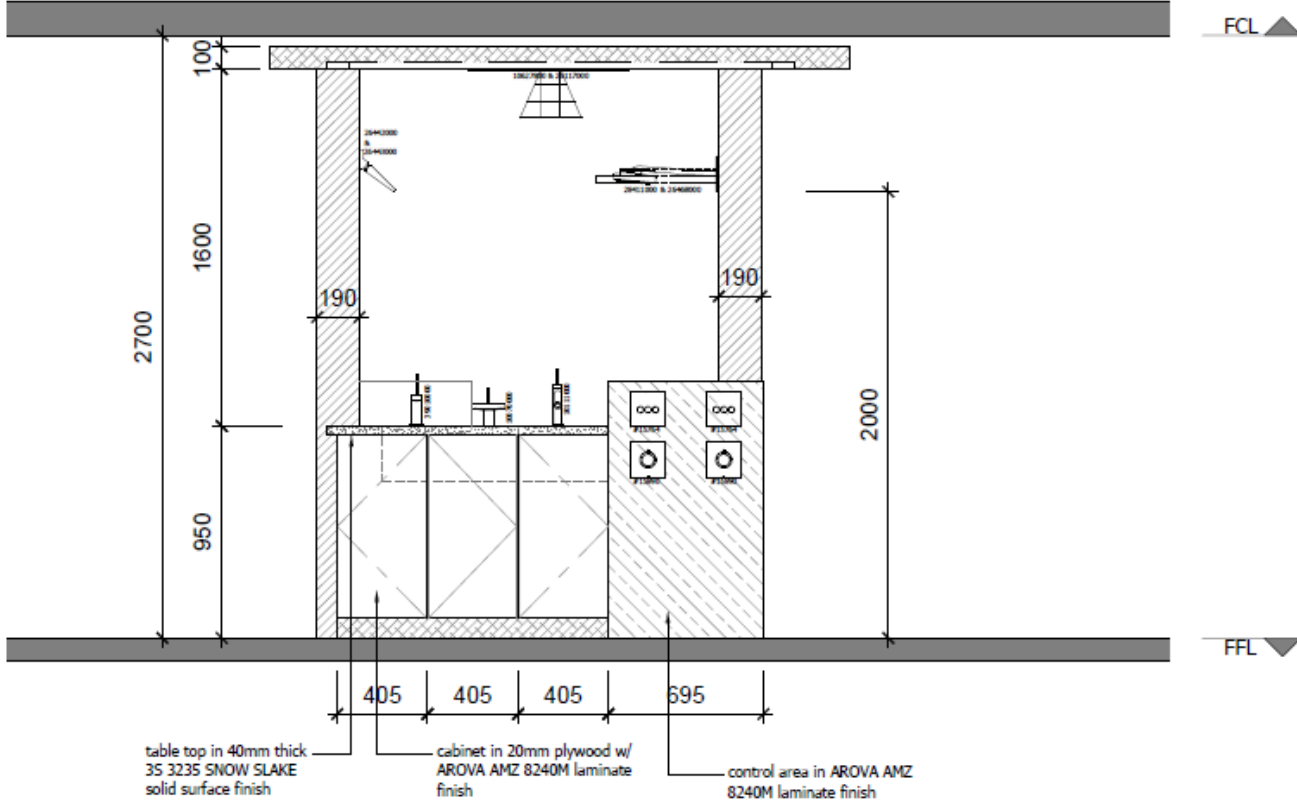

LIVE DEMO ELEVATION A (AS BUILT)
SCALE: 1:20

Customised Live Testing Area

Examples

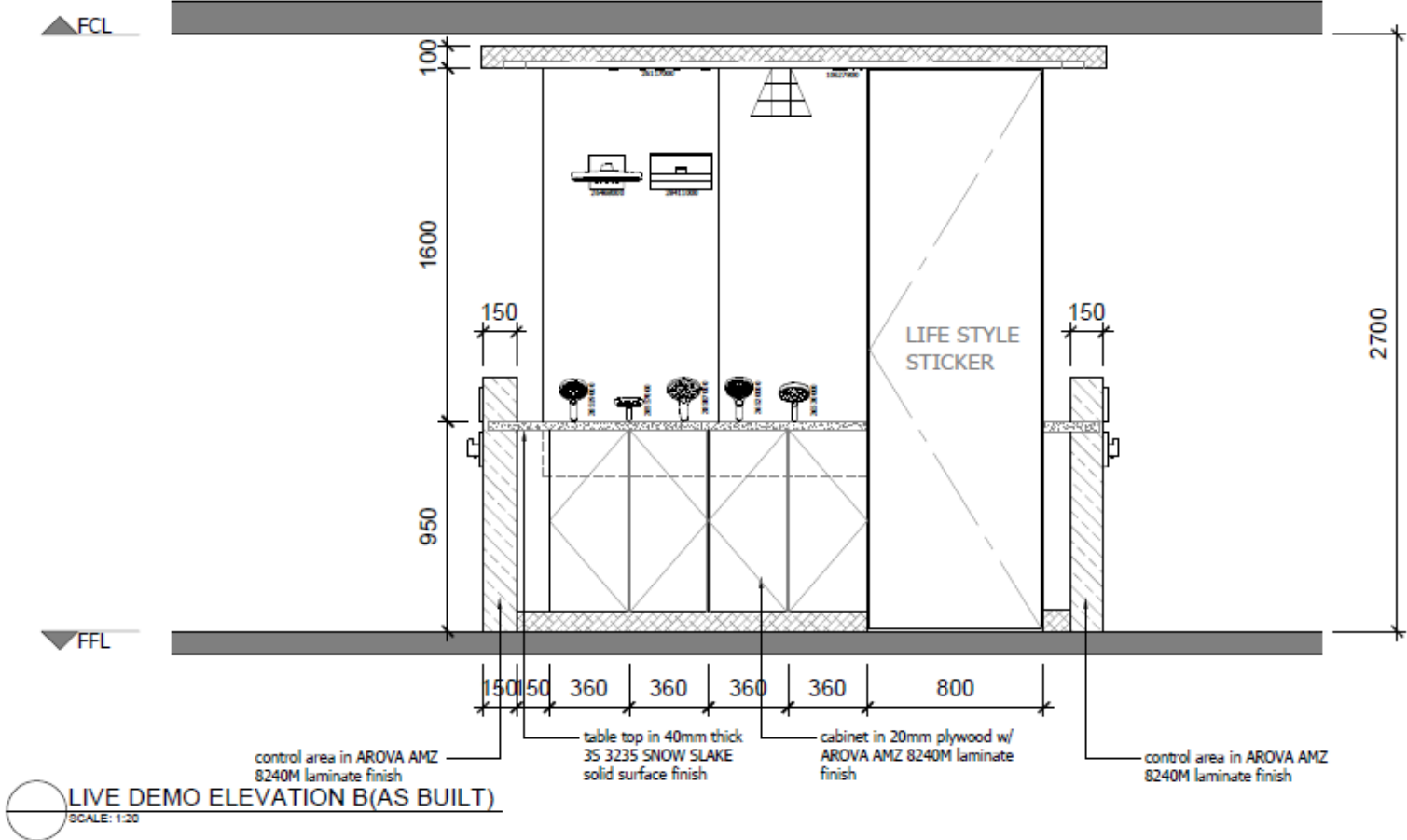

Customised Live Testing Area

Examples

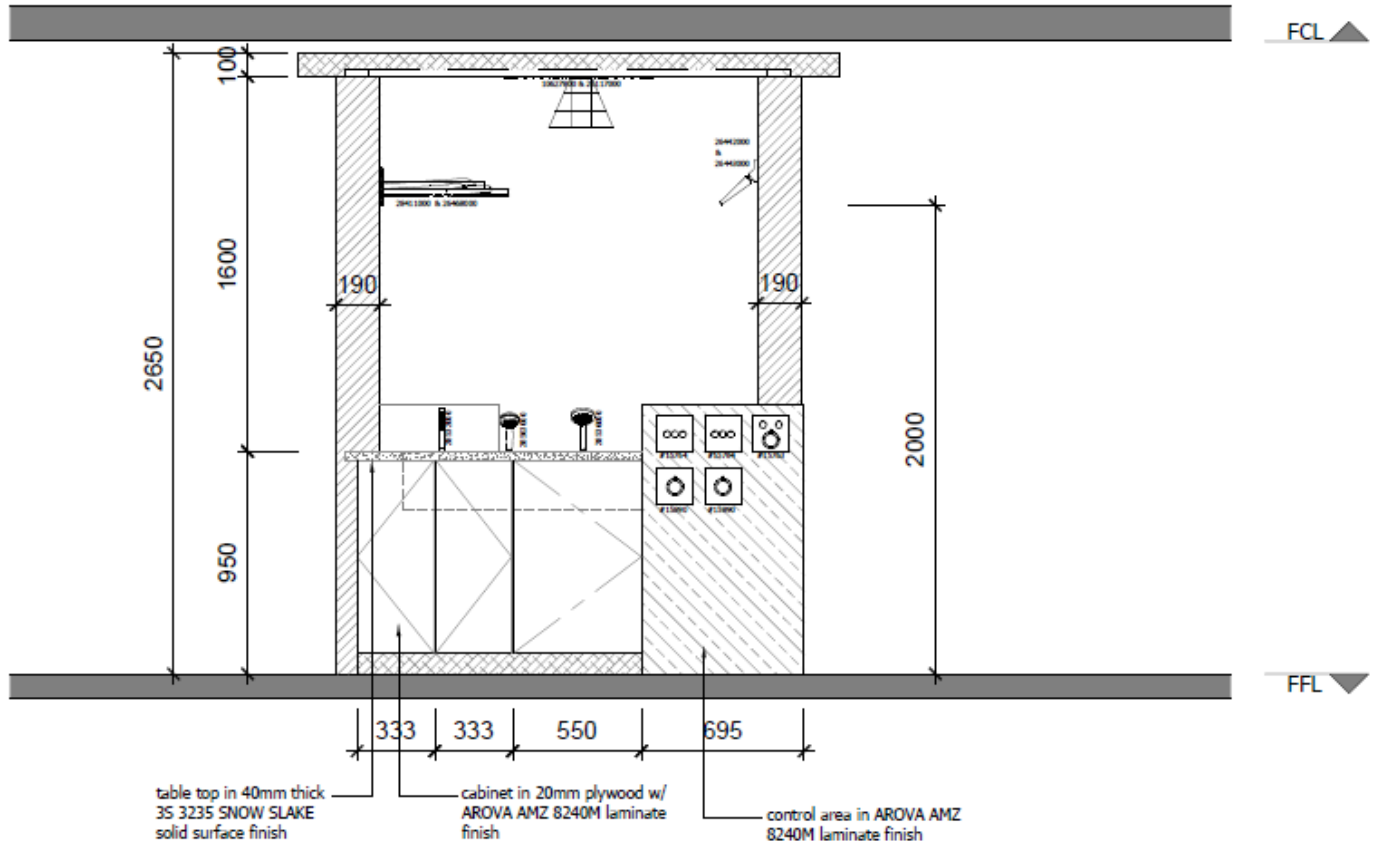

LIVE DEMO ELEVATION C(AS BUILT)
SCALE: 1:20

Customised Live Testing Area

Examples

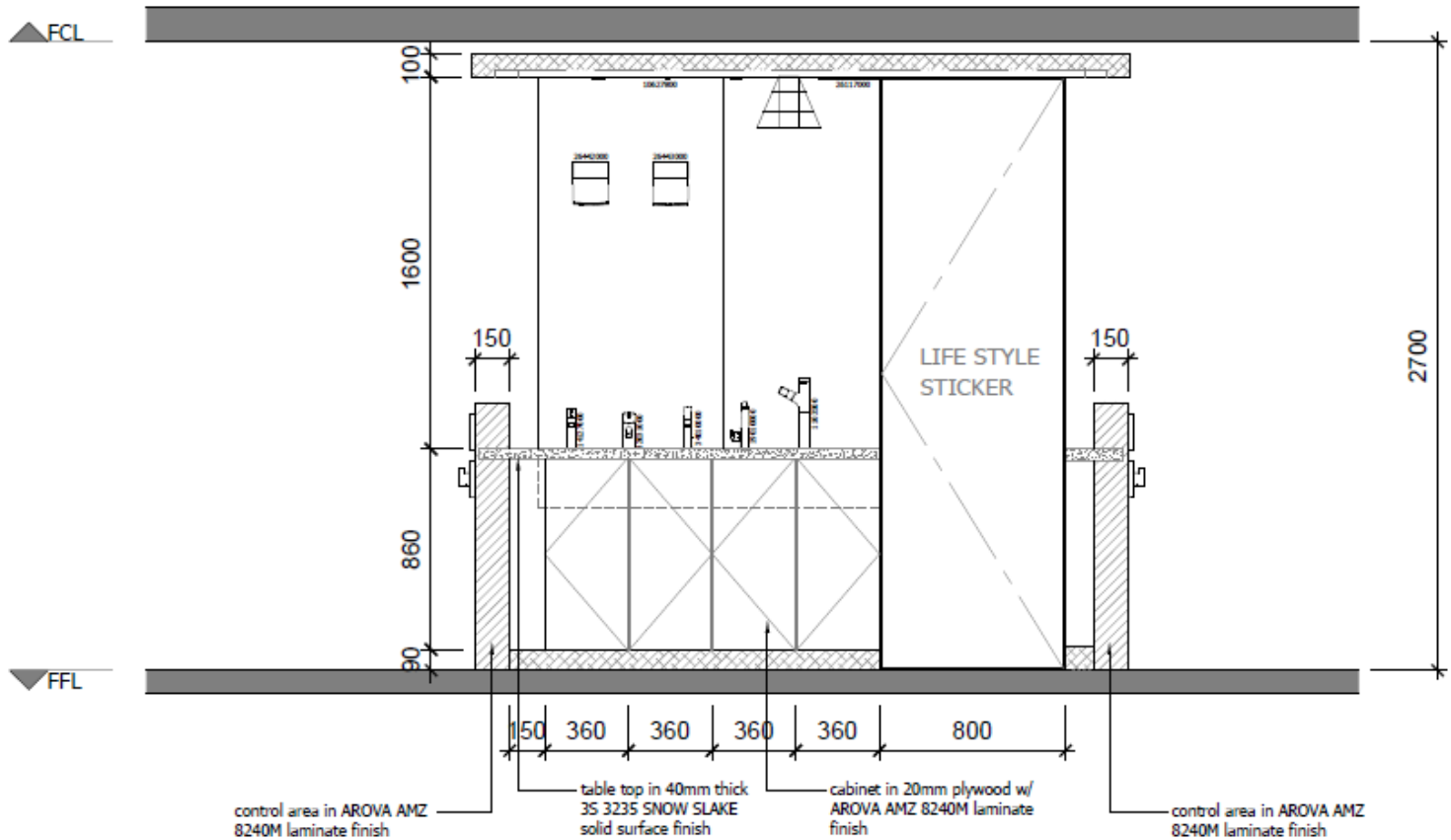

LIVE DEMO ELEVATION D (AS BUILT)
SCALE: 1:20

Customised Live Testing Area

Examples



Customised Live Testing Area

Examples



Customised Live Testing Area

Examples



Customised Live Testing Area

Examples

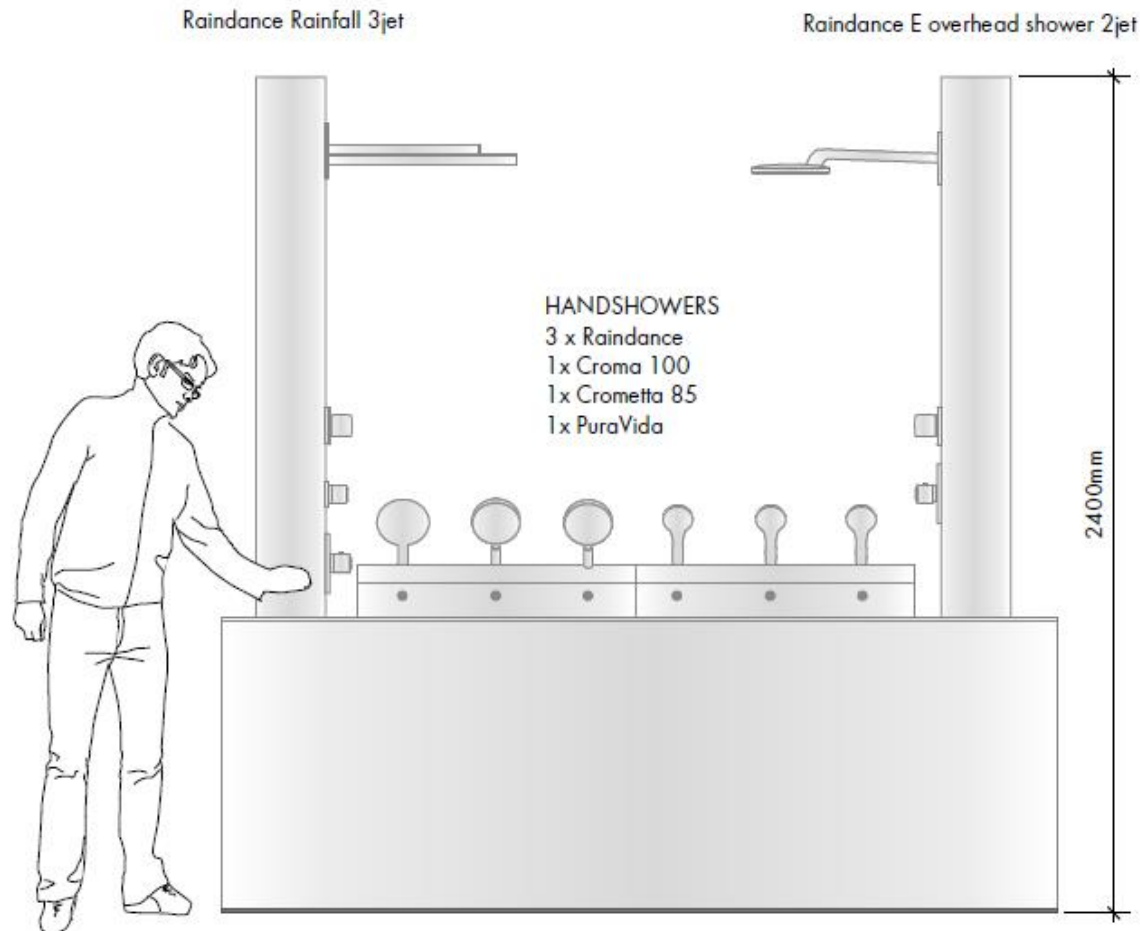

Customised Live Testing Area

Examples

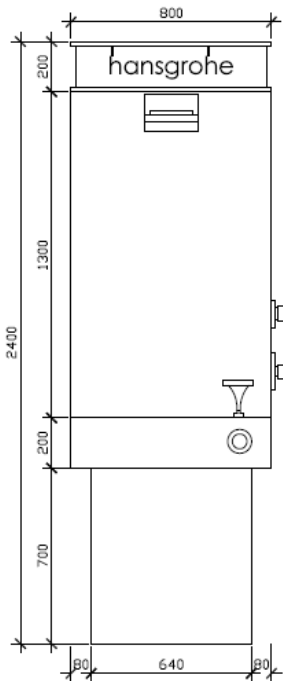

FRONT ELEVATION

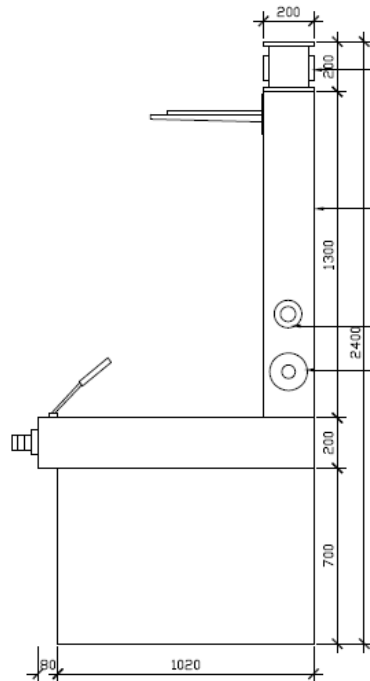

SIDE ELEVATION

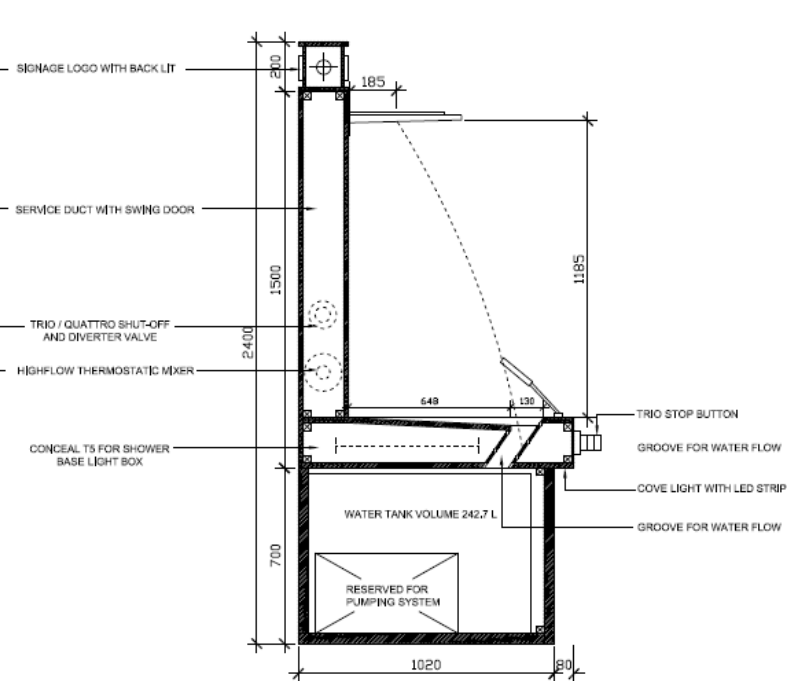

SECTION X-X

Customised Live Testing Area

Examples: Rainmaker Select Fontana #91233000

Inclusive of all the fittings as seen.

You can order this Fontana display with our sales colleagues.

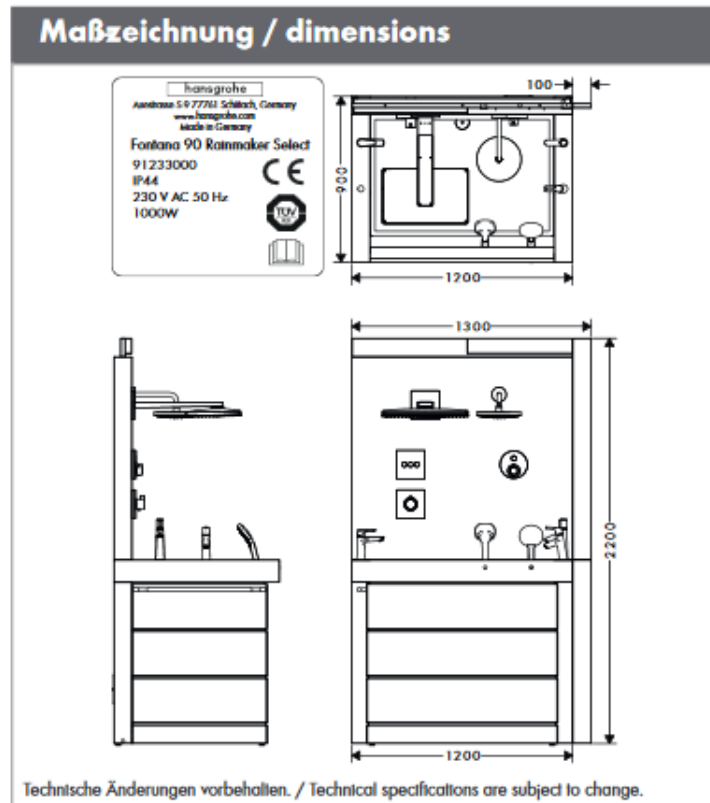

Mini Display Hose

If you would like to use mini display hoses (short Isiflex hoses) to improve the displays in your showroom, you may also order the Article **#86002186**. Please contact CS or our sales colleague.



Chapter 3

Examples of AXOR Displays

AXOR Displays

There are 3 main ways to display AXOR products:

i) Bathroom Situation

ii) Mini Bathroom Situation

iii) Panel Display

Whenever space is available, we strongly encourage you to showcase AXOR products in a Bathroom Situation.

Bathroom Situation



Mini Bathroom Situation

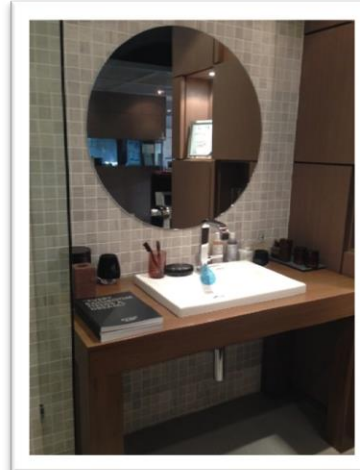

Panel Display



AXOR Displays

What is a Bathroom Situation?

- At least 1 shower area AND 1 basin area
- Proper representation of the collection ambient
- Labelled with line sticker of collection, example: AXOR Urquiola
- Items displayed in a bathroom situation should be from the same collection, unless unavailable



AXOR Displays

What is a Mini Bathroom Situation?

- Either 1 shower area OR 1 basin area
- Proper representation of the collection ambient



AXOR Displays

What is a Panel Display?

- Proper display of products in an appropriate representation
- It is encouraged to include images/descriptions of the designer and collection



AXOR Designer Gallery



AXOR Designer Gallery

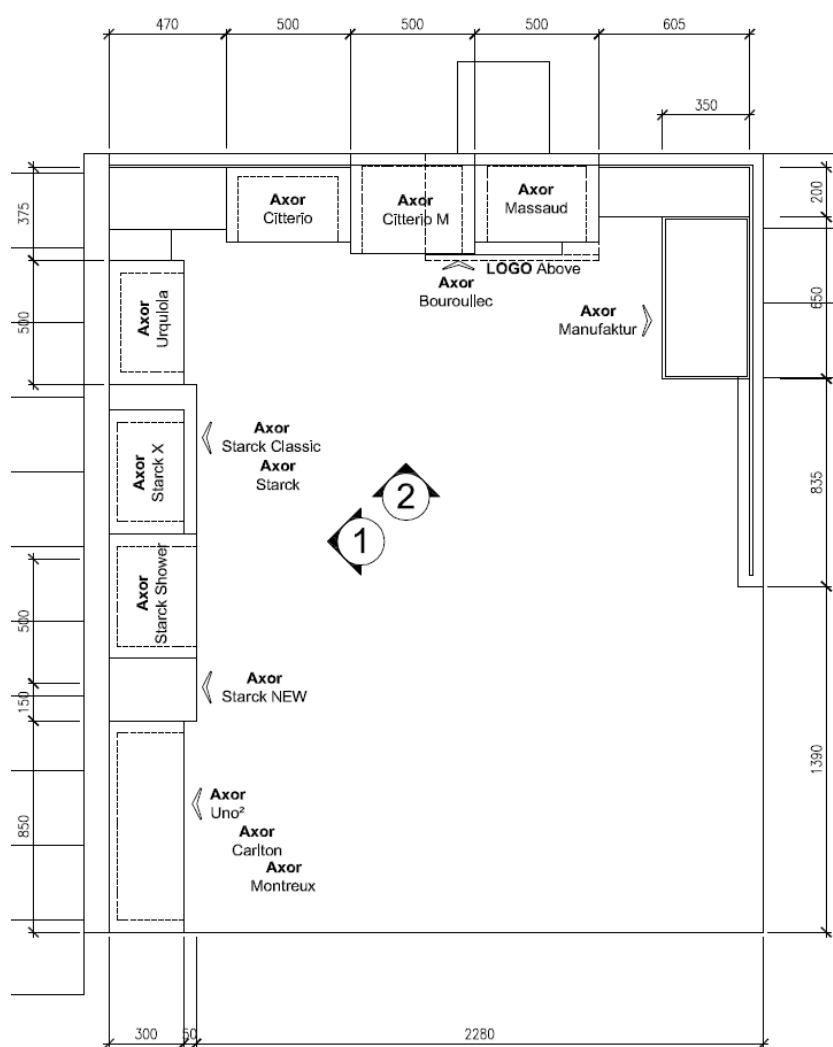

AXOR Designer Gallery

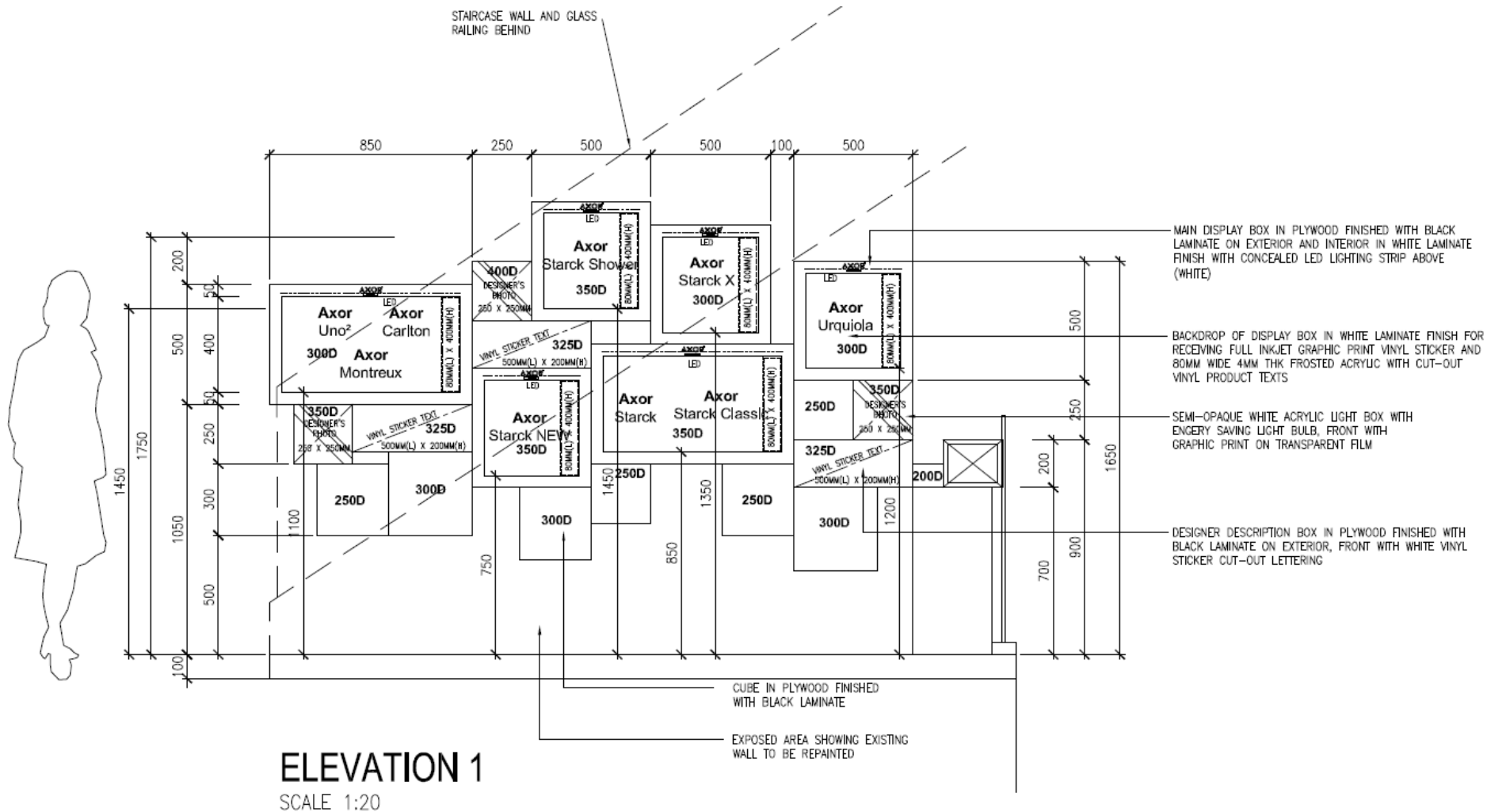

AXOR Designer Gallery

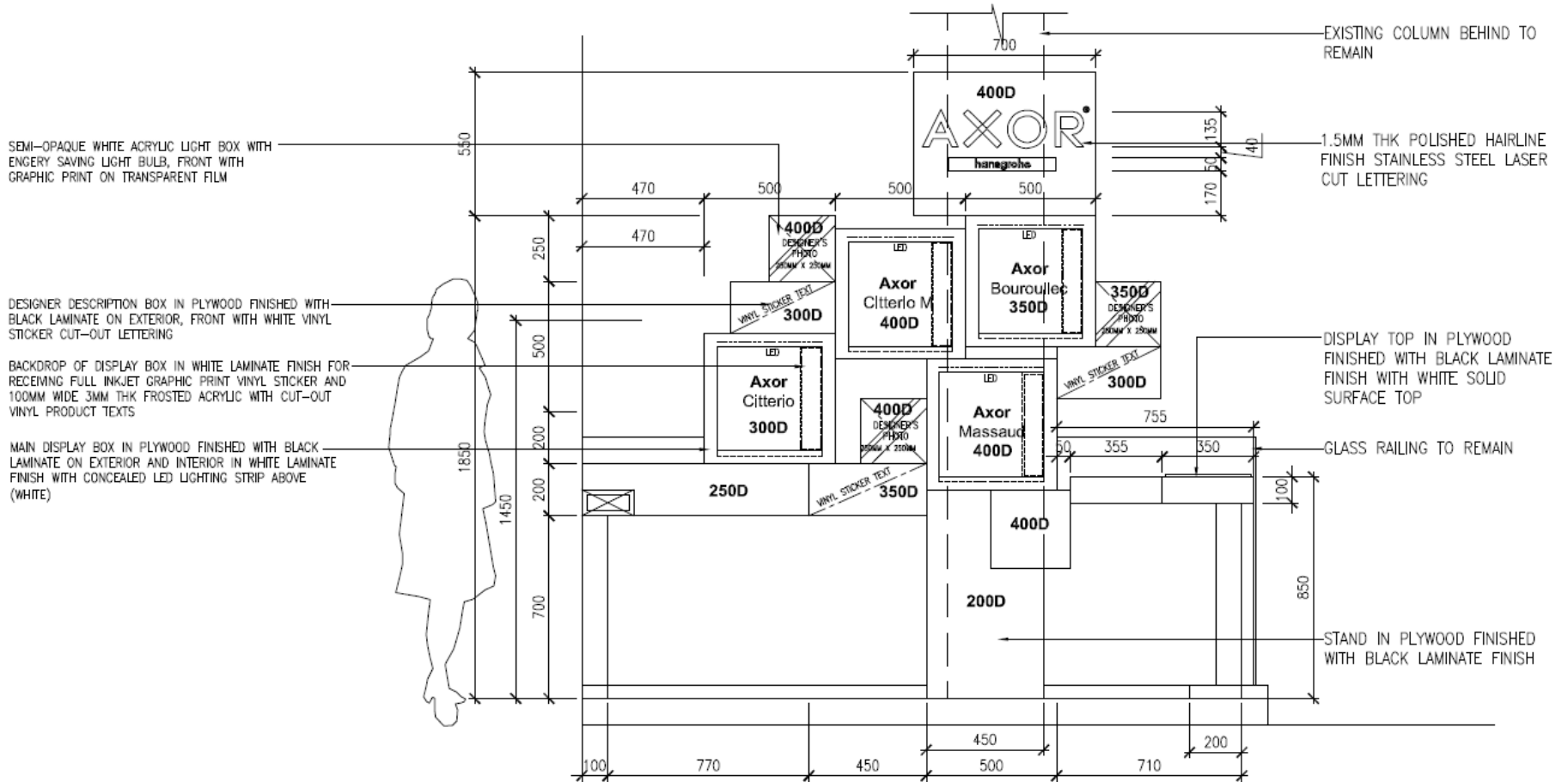

ELEVATION 2

SCALE 1:20

AXOR Designer Gallery

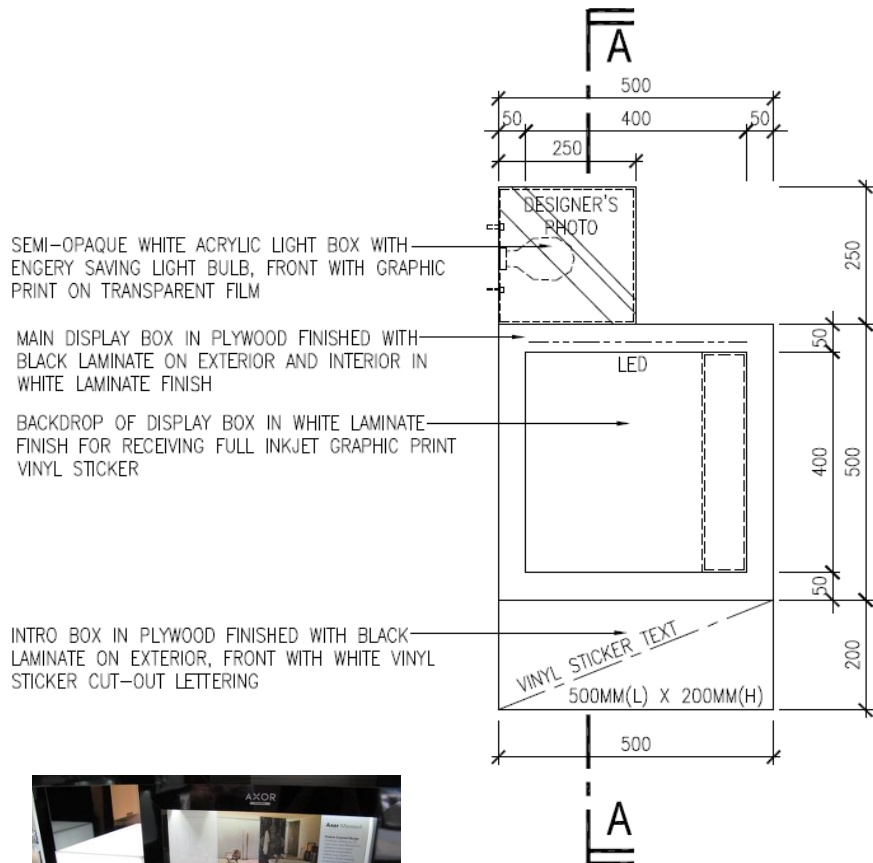

SEMI-OPAQUE WHITE ACRYLIC LIGHT BOX WITH ENERGY SAVING LIGHT BULB, FRONT WITH GRAPHIC PRINT ON TRANSPARENT FILM

MAIN DISPLAY BOX IN PLYWOOD FINISHED WITH BLACK LAMINATE ON EXTERIOR AND INTERIOR IN WHITE LAMINATE FINISH

BACKDROP OF DISPLAY BOX IN WHITE LAMINATE FINISH FOR RECEIVING FULL INKJET GRAPHIC PRINT VINYL STICKER

INTRO BOX IN PLYWOOD FINISHED WITH BLACK LAMINATE ON EXTERIOR, FRONT WITH WHITE VINYL STICKER CUT-OUT LETTERING



FRONT ELEVATION SCALE 1:10

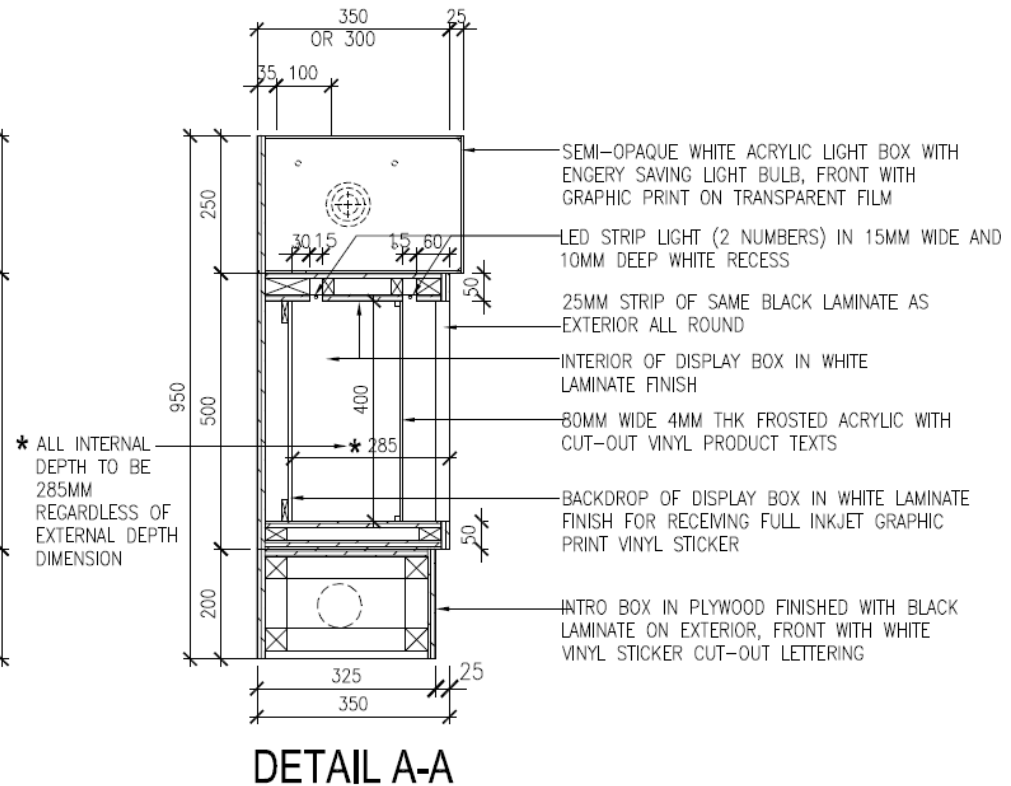

* ALL INTERNAL DEPTH TO BE 285MM REGARDLESS OF EXTERNAL DEPTH DIMENSION

SEMI-OPAQUE WHITE ACRYLIC LIGHT BOX WITH ENERGY SAVING LIGHT BULB, FRONT WITH GRAPHIC PRINT ON TRANSPARENT FILM

LED STRIP LIGHT (2 NUMBERS) IN 15MM WIDE AND 10MM DEEP WHITE RECESS

25MM STRIP OF SAME BLACK LAMINATE AS EXTERIOR ALL ROUND

INTERIOR OF DISPLAY BOX IN WHITE LAMINATE FINISH

80MM WIDE 4MM THK FROSTED ACRYLIC WITH CUT-OUT VINYL PRODUCT TEXTS

BACKDROP OF DISPLAY BOX IN WHITE LAMINATE FINISH FOR RECEIVING FULL INKJET GRAPHIC PRINT VINYL STICKER

INTRO BOX IN PLYWOOD FINISHED WITH BLACK LAMINATE ON EXTERIOR, FRONT WITH WHITE VINYL STICKER CUT-OUT LETTERING

DETAIL A-A

AXOR Designer Gallery



AXOR Starck Organic

Examples



AXOR Starck Organic

Examples

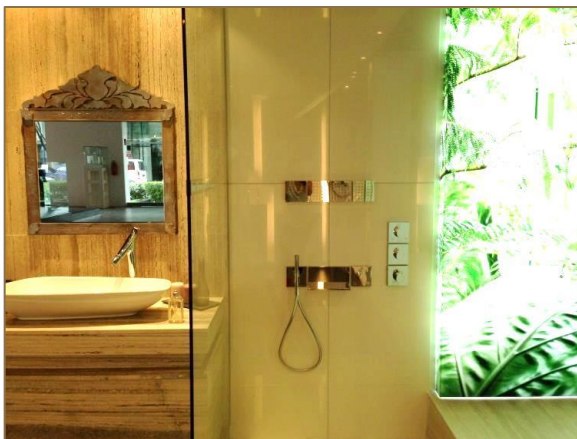

Bathroom Planning Reference:
AXOR Starck Organic Bathroom Planning Brochure
Form-Nr. 84 120 842

AXOR Starck Organic

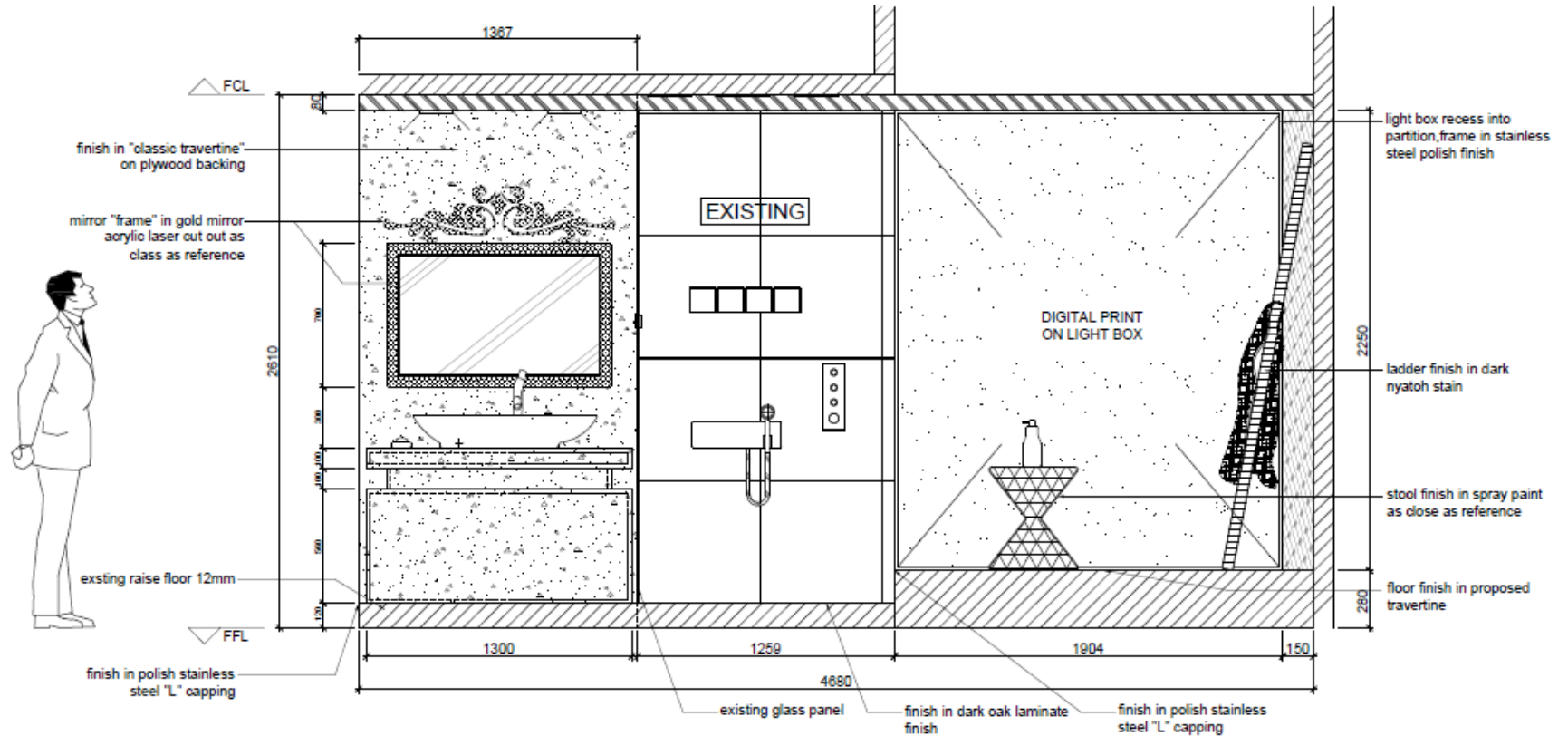

EXHIBITION ELEVATION A
SCALE: 1:20

AXOR Starck

AXOR

Examples



Bathroom Planning Reference:
AXOR Starck ShowerCollection Shower Planning Brochure
Form-Nr. 84 120 637

AXOR Starck

Examples



Examples



Bathroom Planning Reference:
AXOR Starck ShowerCollection Shower Planning Brochure
Form-Nr. 84 120 637

AXOR Bouroullec



Bathroom Planning Reference:
AXOR Bouroullec Information and Inspiration for Professionals
Form-Nr. 84 290 141

AXOR Urquiola



Bathroom Planning Reference:
AXOR Urquiola Bathroom Planning Brochure
Form-Nr. 84 120 699

AXOR Citterio

AXOR



Bathroom Planning Reference:
AXOR Citterio - A new bathroom, new products, new inspirations.
Form-Nr. 84 120 730

AXOR Citterio M

AXOR



Bathroom Planning Reference:
AXOR Citterio M Bathroom Planning Brochure
Form-Nr. 84 090 295

AXOR Massaud

AXOR



Bathroom Planning Reference:
AXOR Massaud Bathroom Planning
Form-Nr. 84 090 283

AXOR Starck V



AXOR Starck V

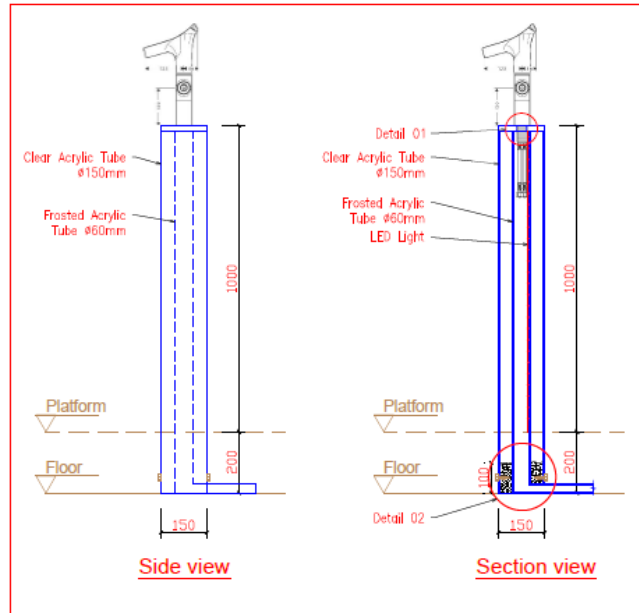

Column Display 01

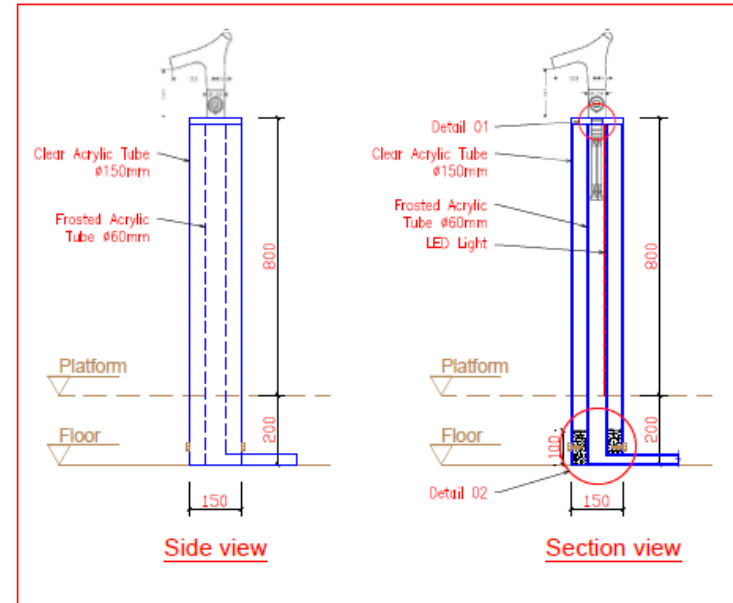

Column Display 02

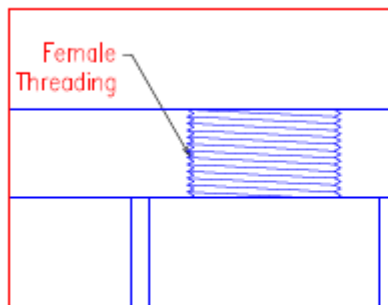

Detail 01

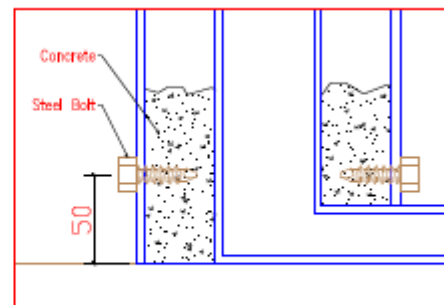

Detail 02

AXOR FinishPlus & AXOR Signature



To showcase the various customisable capabilities of Hansgrohe/Axor, we encourage dealers to showcase the 12 different possible finishes and the different adaptations. Individual display model can also be requested.

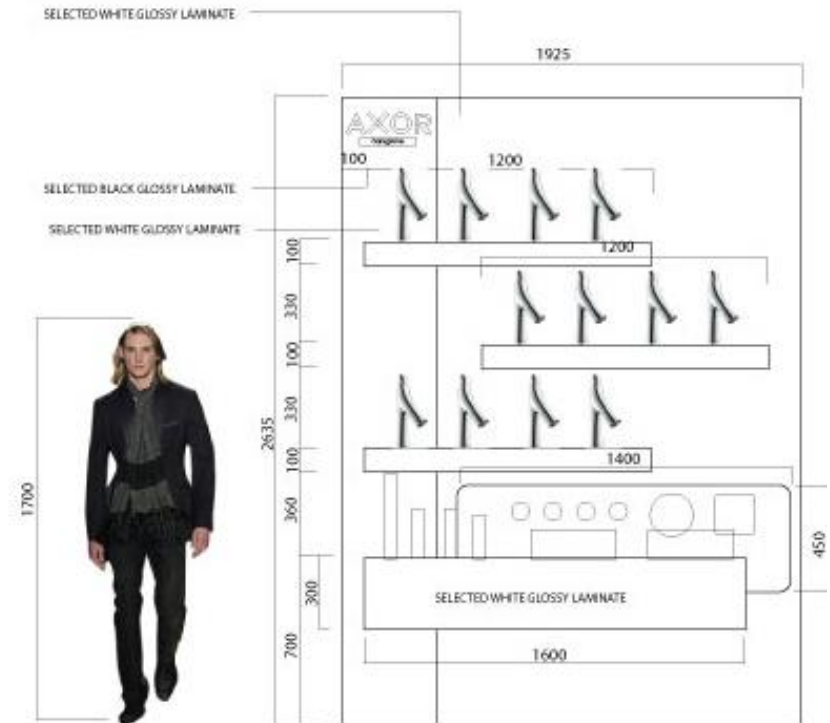

AXOR Citterio E



Bathroom Planning Reference:
AXOR Citterio E Bathroom Planning Brochure
Form-Nr. 84 090 383

AXOR Citterio E

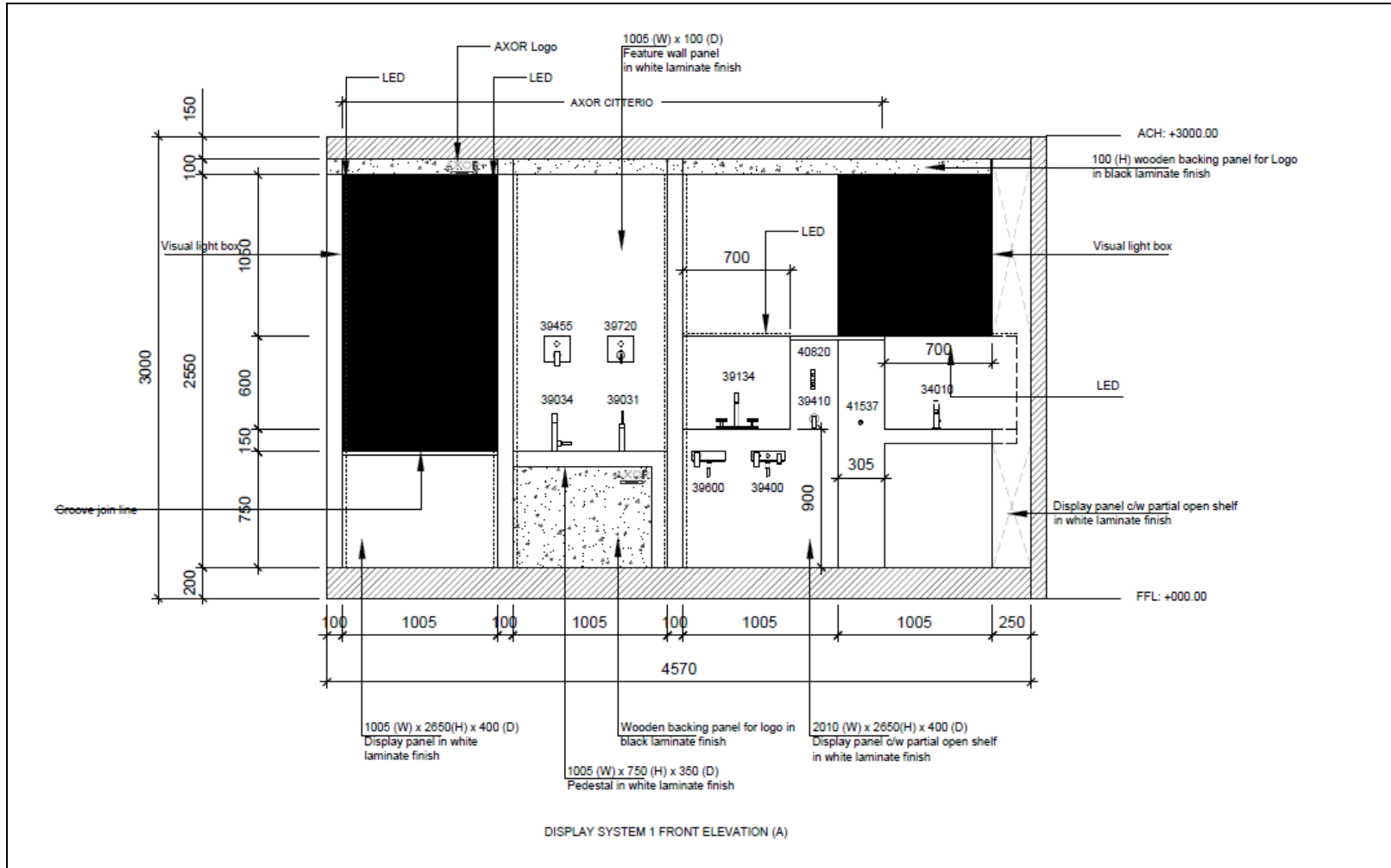

AXOR Citterio E

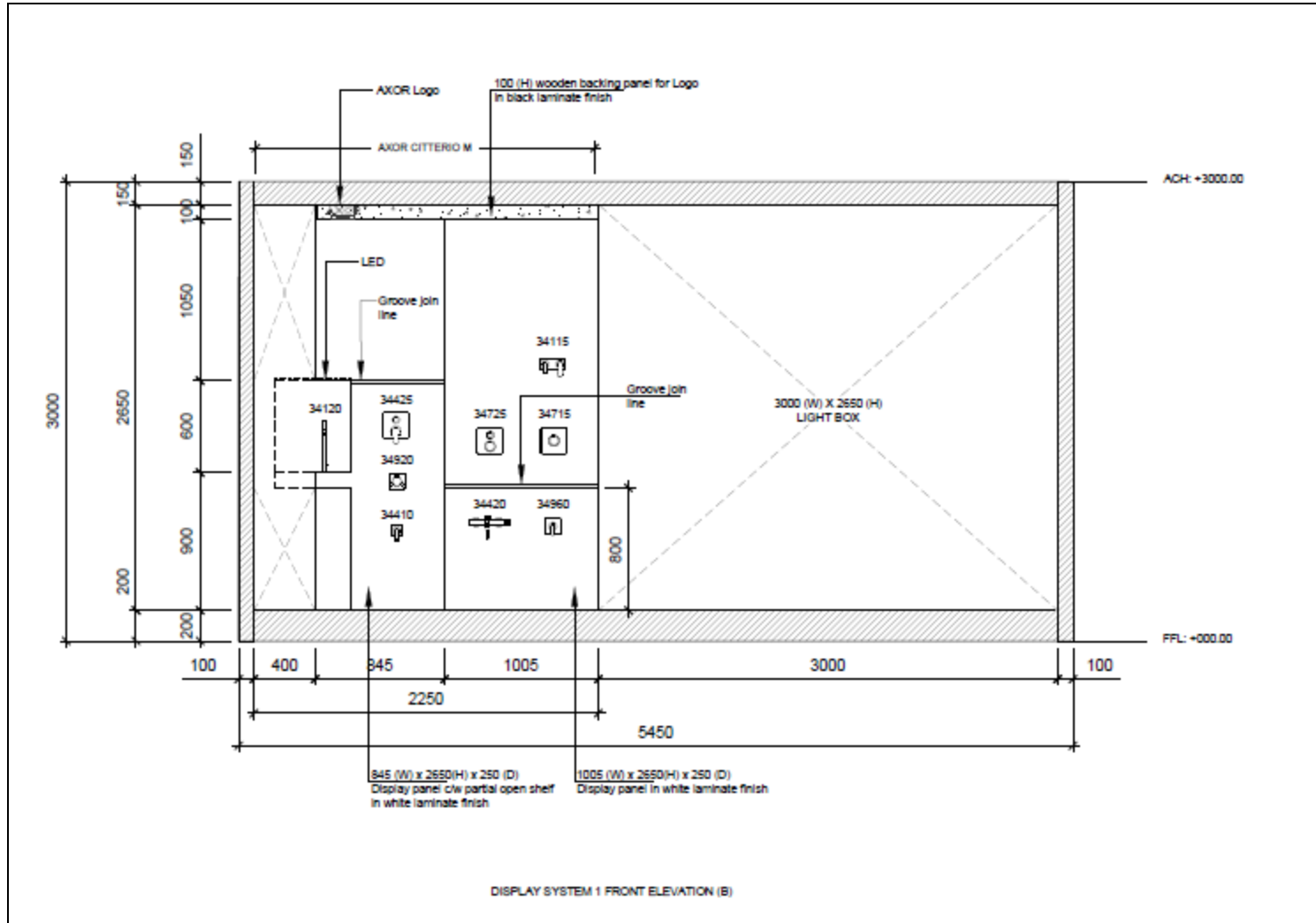

AXOR Citterio E

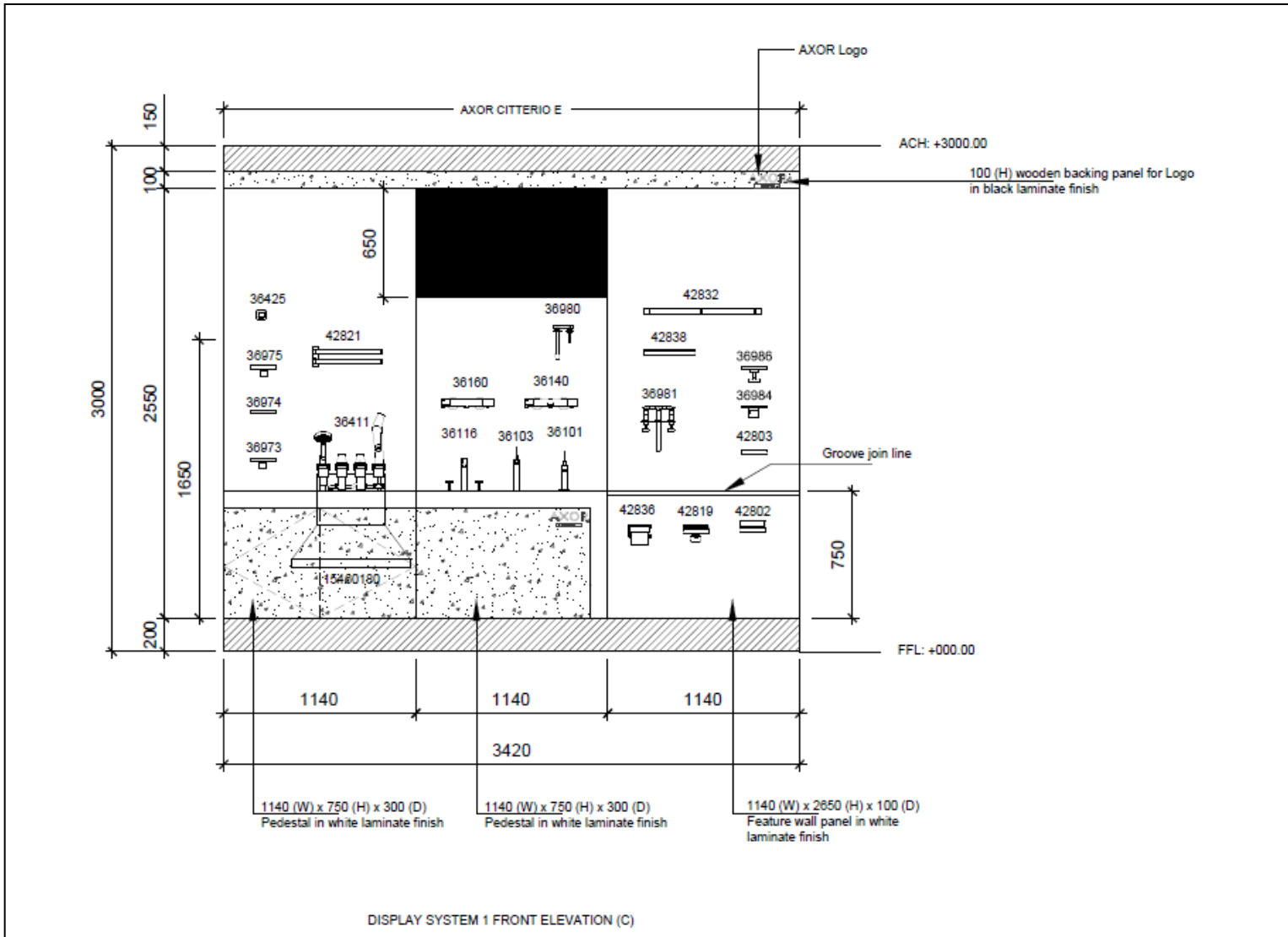

Customised Live Testing Area

Examples: AXOR Fontana 60 with Starck V #91214000
 Inclusive of AXOR Starck V Single Lever Basin Mixer 250 as seen.
 You can order this Fontana display with our sales colleagues.

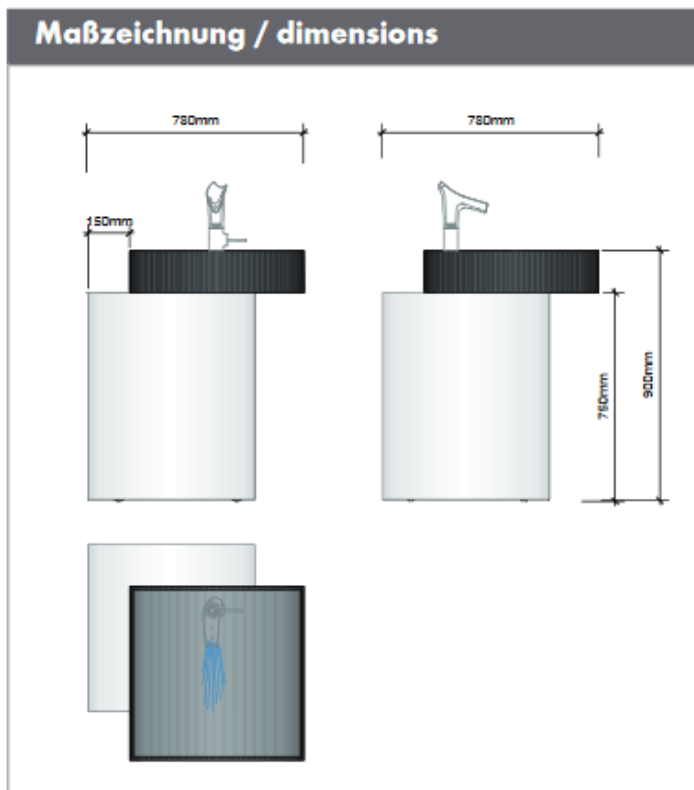

AXOR ShowTec

Attractive

- Clear and slim design
- Eye-catching and inspirational imagery
- Clear structure

Modular and flexible

- Wall mounted and free standing solutions
- Various collection boards
- Multiple configurations and expansion options

Long lasting

- Highest quality standards
- Timeless product presentations showing the AXOR competences
- Easy collection updates possible

Extraordinary

- Effective lighting
- Fascinating illuminated images
- Integrated wash basins creating an ambience atmosphere



ShowTec – AXOR Citterio E



91254000

Free 3 | Dimensions*: 2200mm x 1420mm x 2200mm (2320mm incl. spots)

ShowTec AXOR Citterio E Free 3 illuminated

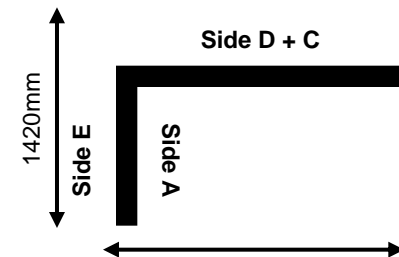

ShowTec – AXOR Citterio E

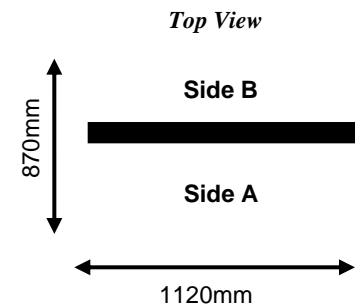

#91260000

Free 1 | Dimensions*: 1120mm x 870mm x 2200mm

ShowTec AXOR Citterio E Free 1 non-illuminated |

ShowTec – AXOR Citterio E

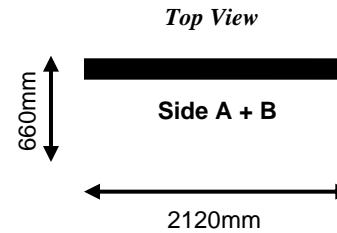

91261000

Wall 2 | Dimensions*: 2120mm x 660mm x 2200mm

ShowTec AXOR Citterio E Wall 2 non-illuminated |

ShowTec – AXOR Uno



91246000

ShowTec AXOR Uno wall 2 illuminated | Wallmounted
 Dimensions*: 2120mm x 300mm x 2200mm | 110V – 230V,
 50 - 60Hz



91244000

ShowTec AXOR Uno free 1 illuminated | Freestanding
 Dimensions*: 1120mm x 500mm x 2200mm | 110V – 230V,
 50 - 60Hz

ShowTec – AXOR Showers



91242000

ShowTec AXOR Showers free 1 | Freestanding Dimensions*:

1120mm x 500mm x 2200mm

ShowTec – AXOR Showers



91243000

ShowTec AXOR Showers wall 2 | Wallmounted | Dimensions*: 2120mm x 100mm x 2200mm

ShowTec – AXOR Kitchen Mixers



91269000

AXOR ShowTec kitchen mixer display| Freestanding |

Dimensions*: 1000mm x 500mm x 1500mm

Chapter 4

Common Mistakes

Common Mistakes

Wrong Logos

- When displaying AXOR products, AXOR logo/branding must be used, and vice versa.

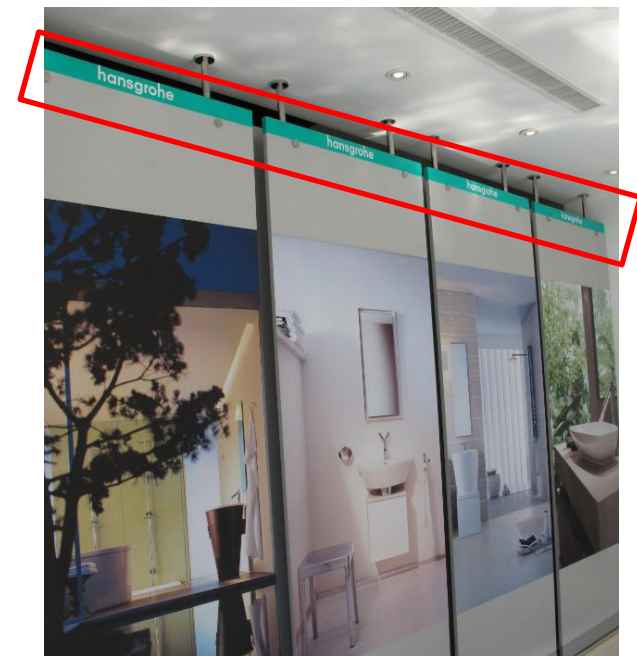

Common Mistakes

Wrong Logo/ Wrong Logo Position

- Logo flag and Logo ribbon should be used appropriately. (see page 10 and 12).



Common Mistakes

Inappropriate or Missing Line stickers

- Line stickers should be used appropriately. (see page 13).

Missing 'AXOR' wording

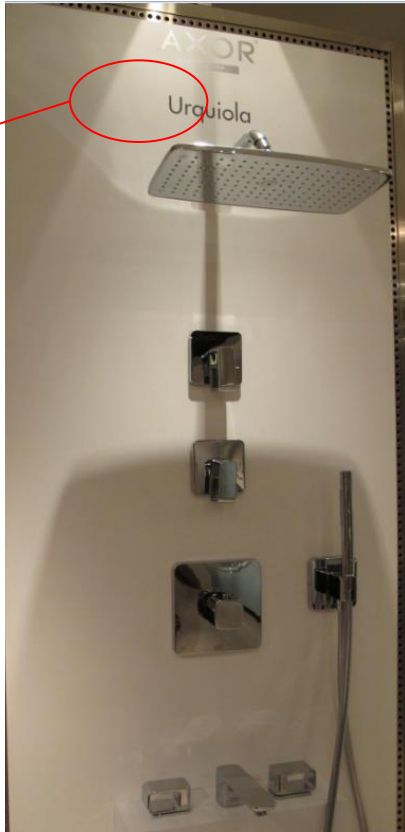

Missing Line Stickers completely



Common Mistakes

Inappropriate or Missing Line stickers

- Line stickers are recommended to be used here. (see page 13).

This is Style stickers,
NOT Line stickers.



Common Mistakes

Improper representation of AXOR Collection in a bathroom situation

- Articles from the same collection are recommended to be used in the same bathroom space, to correctly represent the collection.



Chapter 4

POS Materials

DIY Products POS

Full height display with dummy displays

- This design is recommended for displays of the full range of products from basin mixer to shower bars.

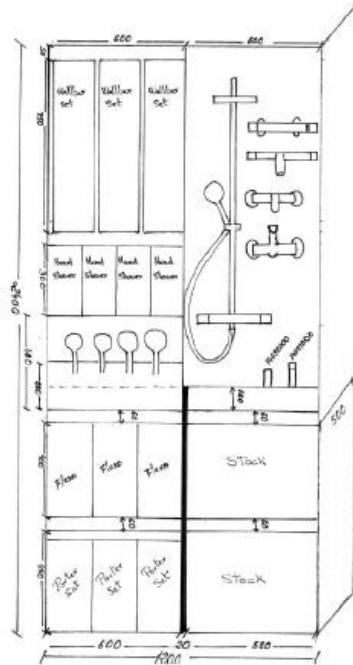

DIY Products POS

Half height display with dummy displays and branding banner

- This design is recommended for added visibility in-store and focused display.

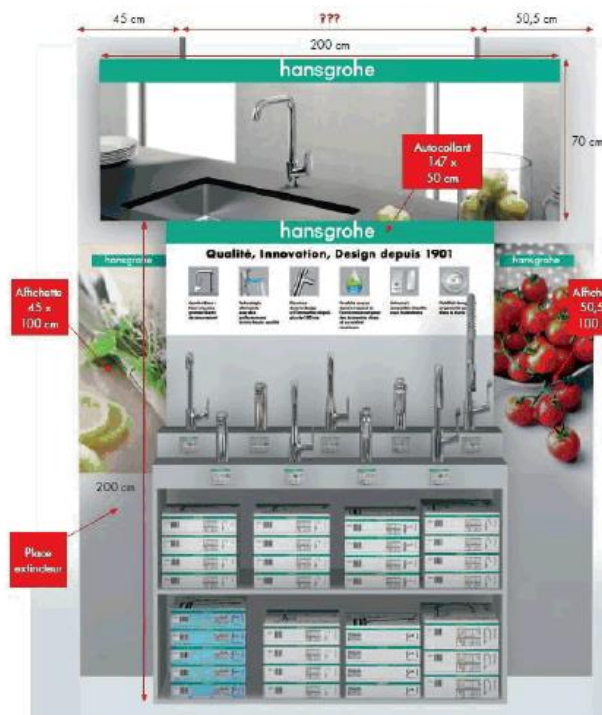

DIY Products POS

Half height display with dummy displays

- This design is recommended for minimal store area.



DIY Products POS

Customisable full height display with branding

- This design is made of removable shelvings and units. Recommended for stores with regular product updates or temporary installation.



POS Support Materials

To help our partners create showrooms that are not only beautiful and impressive, but also effective and sales-generating, we have made several types of POS materials available upon requests.

Some of them are readily printed, others are in soft copies, for you to customise according to your desired size.

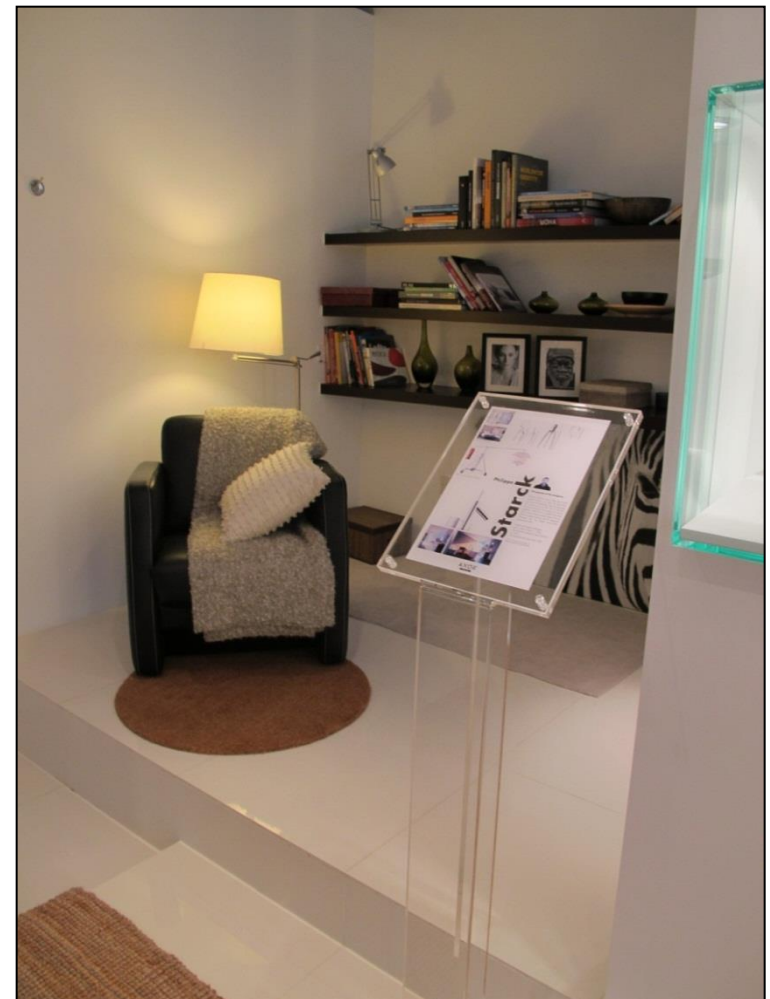

USP Plates

USP plates are available upon request.

Pictures of the POS panels must be submitted before USP plates can be issued.

Products with USP Plates
Talis Select Basin Mixer
ShowerTablet Select 700 Exposed Shower Thermostat
ShowerTablet Select 700 Exposed Bath Thermostat
Rainmaker Select 460 3jet Showerpipe
Rainmaker Select 460 3jet Showerpipe
Rainmaker Select 420 2jet Showerpipe
Croma Select E 180 2jet Showerpipe
Croma Select E Multi Semipipe
Croma Select E Multi Shower Set
Croma Select E Vario Shower Set
Croma Select E 1jet Shower Set
Croma Select S 180 2jet Showerpipe
Croma Select S Multi Semipipe
Croma Select S Multi Shower Set
Croma Select S Vario Shower Set
Croma Select S 1jet Shower Set
Croma Select S 1jet Shower Set
Crometta 100 Multi Shower Set
Crometta 100 Vario Shower Set

Products with USP Plates
Pura Vida 3-Hole Bath Mixer
Pura Vida 4-Hole Bath Mixer
Metris 3-Hole Bath Mixer
Metris 4-Hole Bath Mixer
PuraVida Basin Mixer
Focus Basin Mixer
Talis Basin Mixer
Metris Basin Mixer
Kitchen Mixers
Raindance E Unica 'D Shower Set
Raindance E Unica Shower Set
Raindance Unica 'S Shower Set
Raindance Unica S Puro Shower Set
Raindance Allrounder Set
Raindance Rainbow Set
Raindance Classic Shower Set
Raindance Select Shower Set
Raindance Connect Showerpipe
Raindance Showerpipe
Raindance Select Showerpipe 300
Raindance Select Showerpipe 360
Raindance E420 Showerpipe
Raindance S Showerpanel
Raindance Lift Showerpanel
Skyline Showerpanel
Lift 2 Showerpanel
Croma 100 Unica Reno Lift Set
Croma 100 Vario Shower Set
Croma 100 Multi Shower Set
Croma 100 Classic Shower Set

Products with USP Plates
Croma Showerpanel
Croma 100 Showerpipe
Croma 160 Showerpipe
Croma 220 Showerpipe
Croma 100 Showerpipe Reno
Crometta 85 Multi Shower Set
PuraVida Shower Set
Raindance Select Thermostatic Bath Mixer
Raindance Select Thermostatic Shower Mixer
iControl
iControl mobile
iBox universal
Logis/Logis Classic Accessories
PuraVida Accessories
Raindance Select E 300 Showerpipe
Raindance Select S 300 Showerpipe
Raindance Select S 240 Showerpipe
Raindance Select E 120 / Unica 'S Puro Set
Raindance Select E 150 / Unica'S Puro Set
Raindance Select S 150 / Unica'S Puro Set
Raindance Select S 120 / Unica'S Puro Set
ShowerTablet Select 300 Thermostatic Bath Mixer
ShowerTablet Select 300 Thermostatic Shower Mixer
ShowerTablet Select 300 Combi
Raindance Select S150 Combi
Raindance Select E 120 Combi
ShowerSelect Thermostat
ShowerSelect Valve for 3 outlets
ShowerSelect Thermostat for 1 function
ShowerSelect Thermostat for 2 functions

Silent Salesmen

The working files for the following Silent Salesmen are available upon request. They may be used for any form of POS application i.e. lightboxes, framed posters, large digital print etc.

hangrohe

Comfort at all levels

With our **ComfortZone** range, you can find yourself a mixer of suitable style and height to match your bathroom needs.

<p>ComfortZone 100 - Small yet comforting. This mixer serves the daily purpose of washing your hands and adds a stylish addition to your guest bathroom.</p> 	<p>ComfortZone 110 - If you're looking for greater freedom of movement, this is the right choice. This space offers you a noticeable gain in freedom - everyday.</p> 	<p>ComfortZone 200 - This mixer offers more space, which is ideal for family households, where you can fill up watering cans with the greatest of ease.</p> 	<p>ComfortZone 230 - With its convenient swivel spout, this mixer gives you even greater freedom of movement, allowing you to fill up big bowls.</p> 	<p>ComfortZone 260 - The Highriser offers you the greatest freedom by far, and gives you all the space you need.</p> 
				

Silent Salesmen

hangrohe

AT THE **CLICK** OF A BUTTON
Select Your Shower Pleasure

The diagram features a central circular button labeled "SELECT". Lines radiate from this button to ten different shower components, each with a label:

- Shower Tablet Select 300 Shower Thermostat**
- Shower Tablet Select 300 Bath Thermostat**
- Ecostat Select Shut-off Valve for 3 Functions**
- Ecostat Select Concealed Thermostat**
- Ecostat Select Concealed Thermostat for Hand Shower and Overhead Shower**
- Raindance Select E300 3jet Overhead Shower**
- Raindance Select S240 2jet Overhead Shower**
- Raindance Select Hand Shower E120 3jet**
- Raindance Select Hand Shower S120 3jet**
- Raindance Select E300 3jet Switch Showerpipe**

hangrohe

SELECT YOUR SHOWER PLEASURE

The Ecostat Select Options

The advertisement illustrates how different components are combined to create a complete shower system. It uses plus and equals signs to show combinations of thermostats, showerheads, and showerpipes, with circular images showing a person using the resulting shower setup.

- Shower Tablet Select 300 Shower Thermostat + Hand Shower E120 3jet = Person using Hand Shower
- Shower Tablet Select 300 Bath Thermostat + Hand Shower S120 3jet + Raindance Select Hand Shower S120 3jet = Person using Hand Shower
- Ecostat Select Concealed Thermostat + Shower Tablet Select 300 Shower Thermostat + Hand Shower E120 3jet = Person using Hand Shower
- Ecostat Select Concealed Thermostat for Hand Shower and Overhead Shower + Shower Tablet Select 300 Shower Thermostat + Hand Shower E120 3jet + Raindance Select Hand Shower S120 3jet = Person using Hand Shower

At the bottom center, there is a circular button labeled "SELECT".

Silent Salesmen

hangrohe

Mixer Technology

Bulb Lever
Locks in hot three times the lowering surface of conventional fixing systems.

WaterEminent
Reduces the flow rate by about 30%.

Quick Clean
erator. Injects air into the water, making the spray pleasantly soft.

Safety Function
The integrated hot water restrictor helps prevent scalding.

Ceramic Cartridge
Can be replaced easily and in any position.

Flexible Hoses
Durable and easy to install with 42mm stainless hoses.

Horizontal Pull Rod
Its 200mm horizontal range reduces installation limitations.

hangrohe

Raindance Showers

Air Power
Combines water with a generous amount of air. For a soft, splash-free water jet and rich, full shower drops.

Eco Smart
Keeps the flow to a minimum to save water and energy. For lasting pleasure.

Quick Clean
Removes lime scale deposits simply by rubbing the flexible silicone nubs.

Silent Salesmen

hangrohe

A Spectacular Overhead Shower Experience

Raindance Rainfall.
Experience the natural power of water: The Rainfall is the first horizontal rain panel where you can experience an entirely new shower sensation and enjoy the space to move around freely in all three spray modes - RainAir, Whirl and RainFlow.



Raindance Rainmaker.
Showering in new dimensions: Our multi-functional Rainmaker brings you a very natural experience: water, around a remarkably generous sense of space. The Rainmaker creates the sensation of standing in the warm rain under open skies.



hangrohe

Raindance Select



3 different jet types

Comes with a 'Select' button



- Caresse Air** 
- Soft Rain Air** 
- Refreshing Mixed Jet** 

Silent Salesmen

hangrohe

Indulge In *Every Drop*



Rain Air



Air-entrained drops will help to wash daily life from you, drop by drop.

Rain Air XL



Envelopes your whole body with soft drops.

Whirl



A concentrated spray for massaging specific parts of the body.

Caresse Air



Gives you energy after a challenging day with its dynamic, revitalising massage spray.

Mix



The harmonious combination of gentle shower drops and a dynamic spray.

Rain Flow



A powerful surge spray that makes you feel as if you were standing on your own in a lagoon.

Massage III



A strong, pulsing massage spray.

hangrohe

ONE FOR ALL

iBox® universal

The Basic for all standard and thermostatic solutions

- 1 basic set for all mixer lines of Hansgrohe and Axor
- 1 basic set for all Ecostat Select Finish Sets
- 1 basic set has to be stored only
- 1 basic set that fits to all installation systems, connections and fittings



Silent Salesmen

hangrohe



PERFECT KITCHEN COMPANIONS
COMBINING FUNCTIONALITY WITH BEAUTY

CERAMIC CARTRIDGE
The M3 and M2 ceramic cartridges guarantee long life for the mixer.



QUICKCLEAN
You can easily rub deposits off with your finger.



SIMPLE INSTALLATION
Flexible connection hoses make it easier to install the mixer.



PEX HOSES
The temperature resistant PEX hoses comply with the new drink water regulations. They are microbiologically pure and neutral in taste and smell.





PULL-OUT SPRAY/PULL-OUT SPOUT
The pull-out spray and spout extend to cover an area with a radius of 50 cm. The smooth-flowing fabric hose and the plastic-coated hose weight slide almost noiselessly back into the mixer body. Also, the pull-out spray makes it extremely easy to choose between the two modes - Normal and Spray.



hangrohe

Perfect Kitchen Companions
Combining Functionality with Beauty



Ceramic Cartridge
The M3 and M2 ceramic cartridges guarantee long life for the mixer.



Simple Installation
Flexible connection hoses make it easier to install the mixer.







PEX Hoses
The temperature resistant PEX hoses comply with the new drink water regulations. They are microbiologically pure and neutral in taste and smell.



Quickclean
You can easily rub deposits off with your finger.



Pull-out spray/ pull-out spout
The pull-out spray and the pull-out spout extend to cover an area with a radius of 50 cm. The smooth-flowing fabric hose and the plastic-coated hose weight slide almost noiselessly back into the mixer body. Also, the pull-out spray makes it extremely easy to choose between the two modes - Normal and Spray.



AXOR Designer Signs

Soft copies of AXOR Designer Signs (both portrait and landscape versions) are available upon request.

Philippe Starck

The popstar of the designers

Philippe Starck is one of the best known creative minds of our time. His design of a lemon squeezer in the form of a spider launched him to fame. Many people regard him as having a stroke of genius, which is provocative with his playful and often spectacular style.

- Interior architect and designer
- Born in 1949 in Paris, France
- Founded the company 'Starck Product' in 1979
- Has been working with Axor since 1992

Find out more about Axor Starck at hangrohe-int.com/axor-starck

Find out more about Axor Starck Organic at hangrohe-int.com/axor-starck-organic

Yoo Apartment, N.Y.
Hotel Mama Shelter, Paris

Maisie Cognac stand (cup) (Barcelona)
Jung, Self-kissan squeezer (AUSA)
Louis Chevrolet chair (Frankfurt)
W1400W small white shower head (France)
Axor Starck
Axor Starck Organic
Axor ShowerCollection designed by Philippe Starck

AXOR
DESIGNER SIGN

Axor Starck

The aesthetics of minimalism

In today's hectic world, people yearn more and more for tranquility and simplicity. The Axor Starck bathroom collection focuses on the basics, the enjoyment of water. The principle of reduction can be seen in the basic shapes and clear functions. There are no distractions. The result: a timeless bathroom collection that will never go out of fashion.

Find out more about Axor Starck at www.hangrohe.com.sg/axor-starck

AXOR
DESIGNER SIGN

Axor Starck ShowerCollection

Just mix it

The modular design of the Axor Starck ShowerCollection can be used to transform the shower into a tailor made spa. The simple, customisable system comprising shower heads, mixers and accessories provides almost endless design freedom.

Find out more about the Axor Starck ShowerCollection at www.hangrohe.com.sg/axor-starckshowercollection

AXOR
DESIGNER SIGN

AXOR Designer Signs

Axor Starck Organic - Designed by Philippe Starck
Follow your **Head** and your *Heart*

Organic

user concept

voluminous

3.5l/min

heart

green

efficiency

shower spray

eco

90 nozzles

minimalist

energy

harmony

material

head

comfort

design

AXOR®
hansgrohe

Axor Starck Organic
How much thinking can go into a bathroom collection? And how much heart?

Follow your Heart

Sculptural & characterised by slender beauty

- Unique, organic design
- Handles and mixer body harmoniously melt into one
- New jet former with 90 tiny openings
- Broad jet for thorough wetting of hands
- New flow rate of 3.5 l/min without losing comfort

Follow your Head

Ergonomical & sustainable

- Temperature control is positioned at the top while water volume control is positioned at spout of the mixer
- Allows for pre-adjustment to preferred temperature
- Pre-adjustment prevents water marks
- Gradual water volume control with 2 snap-in positions: 3.5 l/min and 5 l/min
- Requires 1/3 less brass than in conventional mixers
- Decoupled flow of water, which keeps drinking water free from lead and nickel interference

AXOR®
hansgrohe

AXOR Designer Signs



Mandarin Oriental Hotel, Barcelona

Chosen lamp (Flo) Axor Urquiola

Caboche lamp (Foscarini)

Tropicalia Daybed (Moroso)

Anilbodi chaise longue (Moroso)

Patricia Urquiola

The master of style fusion

With her propensity for the decorative, the Spanish designer blends old and new, floral and folkloric. All of her creations share a feminine touch. The international press named her "best designer" in recognition of the refreshing momentum she has given to the market.

- Architect and designer
- Born in Oviedo, Spain, in 1961
- Own design studio in Milan since 1998
- Cooperation with Axor since 2004.

Find out more about Axor Urquiola at: www.hangrohe.com.sg/axorurquiola

AXOR
hangrohe



Axor Urquiola

Awakening your senses

Can a bathroom tell a story? Yes. Let us dream, reminisce and be surrounded by all the things we love that we have accumulated over our lifetime! Patricia Urquiola loves mixing different styles and shapes.

The wash bowl, shaped nostalgically like a tub, evokes memories of times gone by.

Find out more about Axor Urquiola at: www.hangrohe.com.sg/axorurquiola

AXOR
hangrohe

AXOR Designer Signs

Suggested method of presentation:



AXOR

The Hansgrohe History Wall

Having a good long history since 1901 is one of the best aspects of the company, so if possible, dealers are encouraged to put up a Hansgrohe History Wall.

After preparing the artwork based on the shape and size of your wall, please send in your artwork for approval by Hansgrohe Marketing.

hansgrohe

Historical Milestones

1901-1960

1961-1980

1981-2000

2001-Present

FAMILY

The young Hans Grohe (left) with parents and siblings.

Mr Hans Grohe founded Hansgrohe in 1901 in Schiltach, Black Forest, Germany. Since then, Hansgrohe has put forth innovations that have redefined the face of the international bathroom industry. Their commitment to providing quality bathroom solutions has earned them a loyal following of admirers, whom till today share Mr Hans Grohe's passion for the elixir of life.

Hans Grohe, Richard Grohe, Michael Grohe

INNOVATION

GROH-BRAUSE GARNITUR UNICA

SELETA, 1948

Raindance® 2003

RainForend®, 2007

WATER

Environmental protection is one of Hansgrohe's priorities. Their environmental standards significantly exceed the industry-wide regulations and is reflected in the creation of its water-conserving products.

DESIGN

Design is an important part of Hansgrohe's product philosophy. Hansgrohe is the first sanitary company in the world to work with world-renowned designers from as early as the 1970s. Till date, the company has garnered more than 270 international design awards such as Red Dot award, Design Plus award, iF Design award and Good Design award.

Aqua® Massiv and Aqua® Citrus M

QUALITY

Hansgrohe uses only high-quality materials that perfectly complement one another, making the products more durable. Their fittings undergo a process of quality checks, stringent tests and final certification by numerous international authorities.

As the leading innovator in bathroom solutions, Hansgrohe is continuously bringing water enjoyment into people's lives. Over the years it has made significant improvements through innovations that include UNO – the first coloured mixer range, the iBox® universal – the universal solution for all concealed installations, along with the award-winning Raindance®.

Project Reference Wall

Being a recognised international premium bathroom brand, we have compiled major projects in the Asian region into a wall display. You can use this as a strong statement of quality to your customers. It is available upon request.

VIETNAM
Sheraton Saigon Hotel and Towers, Hotel Pullman Saigon Centre

THAILAND
Grande Centre Point Hotel Terminal 21, Mandalay Beach Villas, The Siam Bangkok

SINGAPORE
Resorts World, Hotel Michael, Hard Rock Hotel, Coccolaris & Festive Hotel, Man Jervis, Hamilton Scotts

INDONESIA
Raffles Residences Jakarta, Ciputra World 1 Jakarta

KOREA
Turisia Ferries, Park Hyatt Busan

TAIWAN
Millennium Vee Hotel, W Hotel Taipei

MALAYSIA
Sunway Palazzo, The Reserve, The Troika

COMMERCIAL
List of commercial projects including: The Prime Minister's Office, The National Assembly, The National Parliament, etc.

RESIDENTIAL
List of residential projects including: The Prime Minister's Office, The National Assembly, The National Parliament, etc.

2 metres

3 metres

Chapter 5

Logo Applications in Advertisements & POS items

AXOR

Logo Applications

Logo bar and logo band Hansgrohe brand

Hansgrohe is the brand most closely associated with our company. It represents a range of products from showers, bathroom and kitchen faucets to installation technology. Through constant innovation, the Hansgrohe brand is continually setting new trends in the bathroom industry.

The logo appears on all print and advertising material related to the Hansgrohe brand and our company.

The logo of the hansgrohe brand is a so-called “wordmark”. It is available in two versions, for use as described below.

1) Logo flag (= Standard)

The wordmark is always used in the form of a “flag”.



2) Logo ribbon (= Exception)

The wordmark is used in the form of a logo ribbon in exceptional cases.



AXOR

Guidelines for Logo Flag

- **Logo Flag (Standard)**

The so-called “logo flag” is the standard logo of the hansgrohe brand.

It should be integrated into all means of communication whenever possible to ensure the recognition of our brand. The word “hansgrohe” is centred within the logo.



- **Placement**

The logo flag is always right-aligned. It should only be left-aligned in exceptional cases (such as a trade fair booth).

AXOR

Guidelines for Logo Ribbon

- **Logo ribbon (exceptional cases)**

The so-called logo ribbon is a derivative of the existing logo flag at a ratio of 6.5:1. The green background is extended on both sides similar to a ribbon. This logo version may only be used in exceptional cases, such as at the POS or to design packaging.



- **Placement**

The logo ribbon is always to be placed at the upper edge.

Use of hansgrohe Logo

Objekthöhe in mm / Height of object in mm

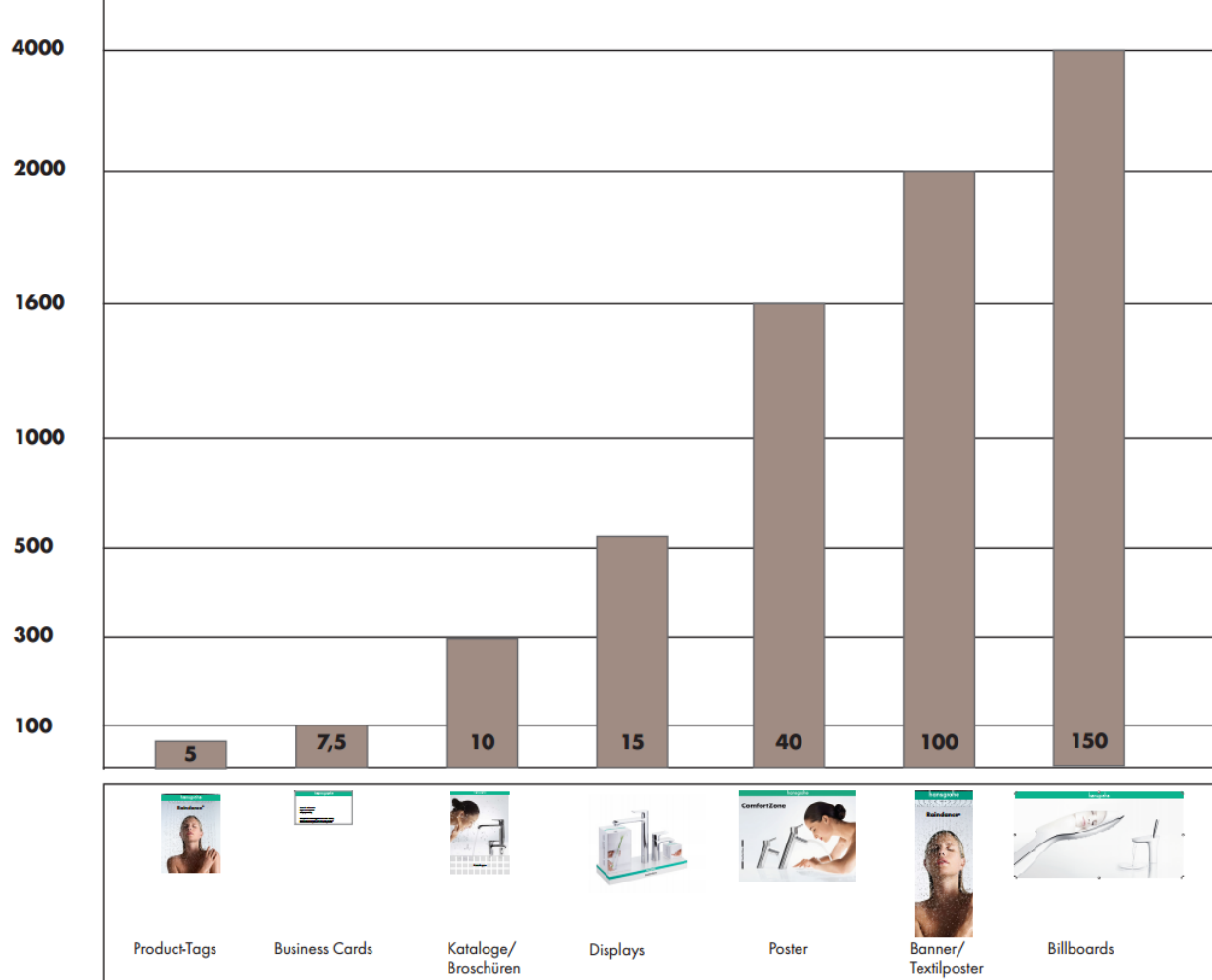

AXOR

Logo Applications

Application of the hansgrohe Logo

The logo band is always positioned at the top of a communication tool. There it has a fix position and doesn't get lost...

Both logo versions can be used in colour or black/white.

The free space around the Hansgrohe logo is set at 21 mm (= 1 square of the tile grid). No other elements or texts may be positioned in this space.

Positive presentation

Coloured presentation:

Bar or band in spot colour HKS 53, alternatively CMYK (95% C, 0% M, 60% Y, 0% K) or Pantone Green C
Hansgrohe lettering negative white



Black/White presentation:

Colour of bar or band 100% black
Hansgrohe lettering negative white



Negative presentation

Black/White presentation:

Colour of bar or band negative white
Hansgrohe lettering 100% black



AXOR

Logo Applications



The logo is always surrounded by a minimum amount of empty space. No other graphic elements may be placed in this area. The minimum empty space on all sides corresponds to 1.5 x the capital letter height.



Chapter 6

Additional Showroom Recommendation

AXOR

Price Labelling Systems

DISPLAY PANELS/PEDESTALS

Small frosted acrylic tabs with clear sticker labels

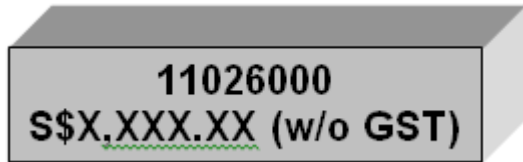

Acrylic Size: 12mm (H) x 50mm (L) x 5mm (D)

Sticker Size: 12mm (H)

*Only indicate price of finished set
(Price of concealed parts to be
advised by sales person separately)*

BATHROOM SITUATIONS

A6-size acrylic stands with colour-printed inserts

- Axor Urquiola Single Lever Basin Mixer**
DN15 Wall-mounted
 Article No: 11026000
 Price: \$ X,XXX.XX
- Basic Set for above Basin Mixer**
 Article No: 10902180
 Price: \$ XXX.XX
- Axor Urquiola Soap Dish**
 Article No: 42433000
 Price: \$ X,XXX.XX
- Axor Urquiola Wash Basin 625mm**
Wall-mounted, molded mineral
 Article No: 11302000
 Price: \$ X,XXX.XX

Prices subjected to GST.

AXOR

Other Suggestions...



>Research shows that customers dwell longer in shops with better ambience, resulting in greater sales. Here are some of our suggestions to improve ambience at any Hansgrohe showroom.

- 1) Create “customer space” i.e. resting area
- 2) Use plants to “soften” the environment
- 3) Use appropriate showroom lighting
- 4) Stimulate their 5 senses

Sight - have beautiful displays with carefully selected accessories

Sound - play contemporary music in English or European language; non-vulgar and no heavy metal

Smell - use fragrance / aroma therapy

Taste - serve refreshments i.e. good quality coffee

Touch - use only high quality materials for displays and accessories

Other Suggestions...

Make the best use of your existing showroom toilets to showcase the Hansgrohe or AXOR collection. Experiencing the brand in actual environment could be your strongest sales tool. This is also especially useful for showrooms with space constrain to create a bathroom situation.

Examples from Singapore Hansgrohe Showroom



*Male Toilet
AXOR Citterio*



*Ladies Toilet
AXOR Bouroullec*



*Ladies Toilet
PuraVida*



*Men Toilet
Metris*

AXOR Contact

hansgrohe

hansgrohe

For more information, please contact:

Hansgrohe Pte Ltd
69 Mohamed Sultan Road
Singapore 239015

Mingni He (Ms)
+65 6933 8665
Mingni.he@hansgrohe.com.sg

www.pro.hansgrohe.com.sg