

DETAILS MATTER



everyday inspiration SPRING 2016

“Wij houden van design, van de combinatie van een prachtig ontwerp met een functionele toepassing. Het is ons vak om 100% aandacht te geven aan de details van de badkamer en het toilet. Het is onze hoofdactiviteit, het is onze passie”.

In 1885 opgericht, dus al 131 jaar actief met badkameraccessoires. Geesa is marktleider in Nederland in het professionele segment (installateurs en badkamerspecialisten) en toonaangevend in export naar nog eens 65 landen. Deze positie hebben we bereikt door consequent op kwaliteit in te zetten. Die kwaliteit is van doorslaggevend belang gebleken de afgelopen jaren. Vandaar ook dat we op onze chroomproducten een garantie kunnen geven van maar liefst 12 jaar. Het assortiment wordt 100% ontwikkeld in Amersfoort.

“We love design, the combination of a magnificent design and its functional application. It is our job to pay 100% attention to bathroom and lavatory details. It is our core activity, as well as our passion”

Founded in 1885, Geesa has been active in the field of bathroom accessories for 131 years and is a market leader in the Netherlands in the professional segment (fitters and bathroom specialist shops) and authoritative in the export to 65 other countries. We have achieved this position by consistently targeting quality. Quality has proven to be of decisive importance in recent years, which is why we can offer a 12-year warranty period for our chrome products. The entire selection is developed in Amersfoort.

GEESA
GEESA
GEESA



DETAILS MATTER



MIRROR: A MAGNIFICENT REFLECTION OF DESIGN

Een gloednieuwe badkamer in een nieuw huis, een renovatietoilet, een complete verbouwing of alleen het vernieuwen van enkele elementen; ieder proces vraagt om oriënteren, informatie verzamelen en keuzes maken om uiteindelijk uw badkamerdroom waar te maken!

Tussen alle 'grote' sanitair-artikelen zoals baden, wc's en meubelen zijn onze producten kleine details. Maar wel dé details die uw badkamer naar een hoger niveau kunnen tillen. De finishing touch!

We kunnen niet voor u bepalen wat uw persoonlijke smaak is, maar we kunnen u wel helpen uw keuzes te maken, met ons volledige assortiment badkameraccessoires. Van spiegels tot zeepdispensers en van toiletborstels tot planchetten. Prachtige ontwerpen met een functionele toepassing. Om elke dag van te genieten!

A brand-new bathroom in a newly built house; a renovated lavatory; a complete alteration or the mere renewal of some elements: each new process requires orientation, information and decisions to realise your bathroom.

Our products constitute small details among the 'large' bathroom articles, such as baths and furniture, but these are the details that can bring your bathroom to a higher level and provide the finishing touch.

We cannot dictate your personal taste, but we can help you make your choices with our entire selection of bathroom accessories, from mirrors to soap dispensers and toilet brushes to shelves, each one beautifully designed with a functional application you will enjoy every day.

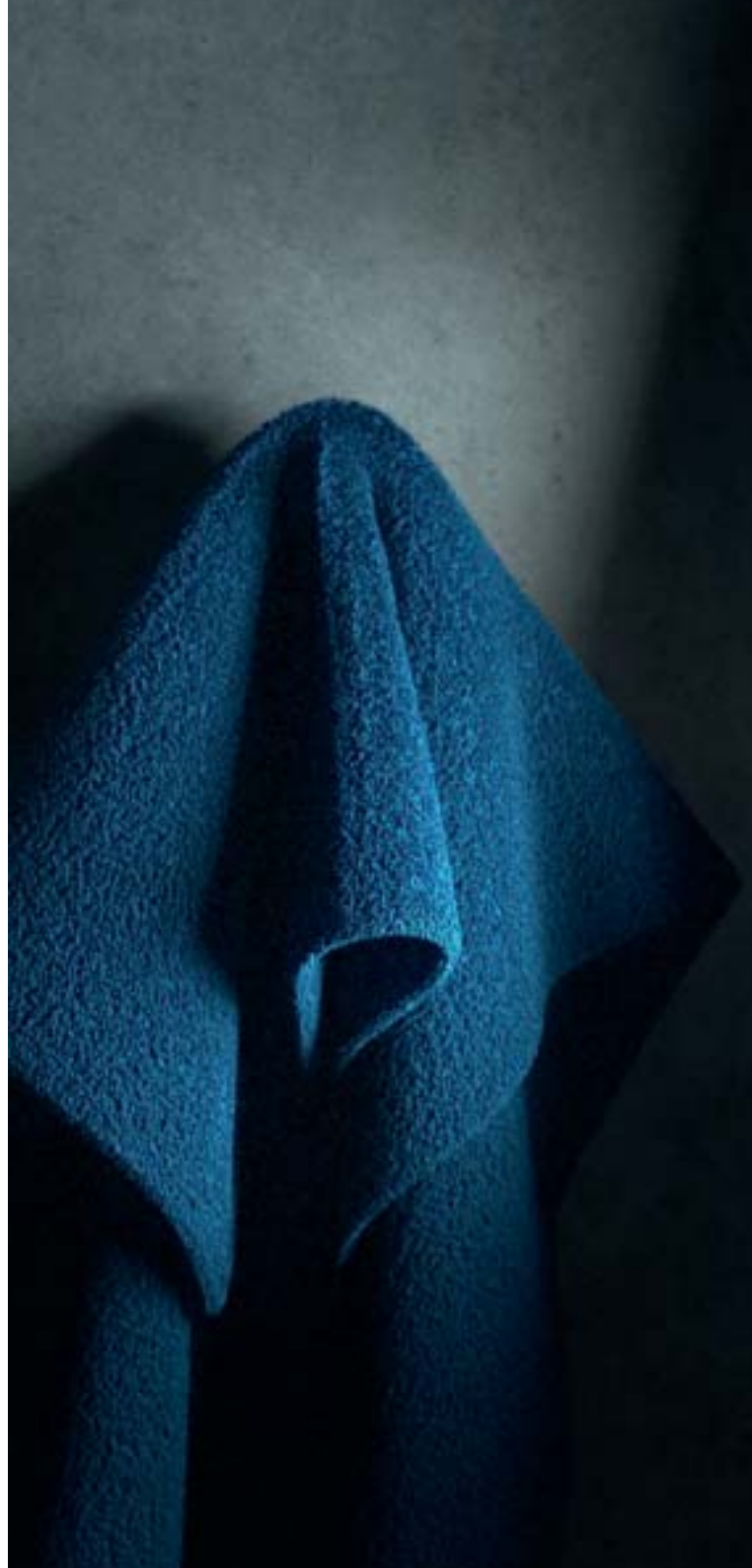

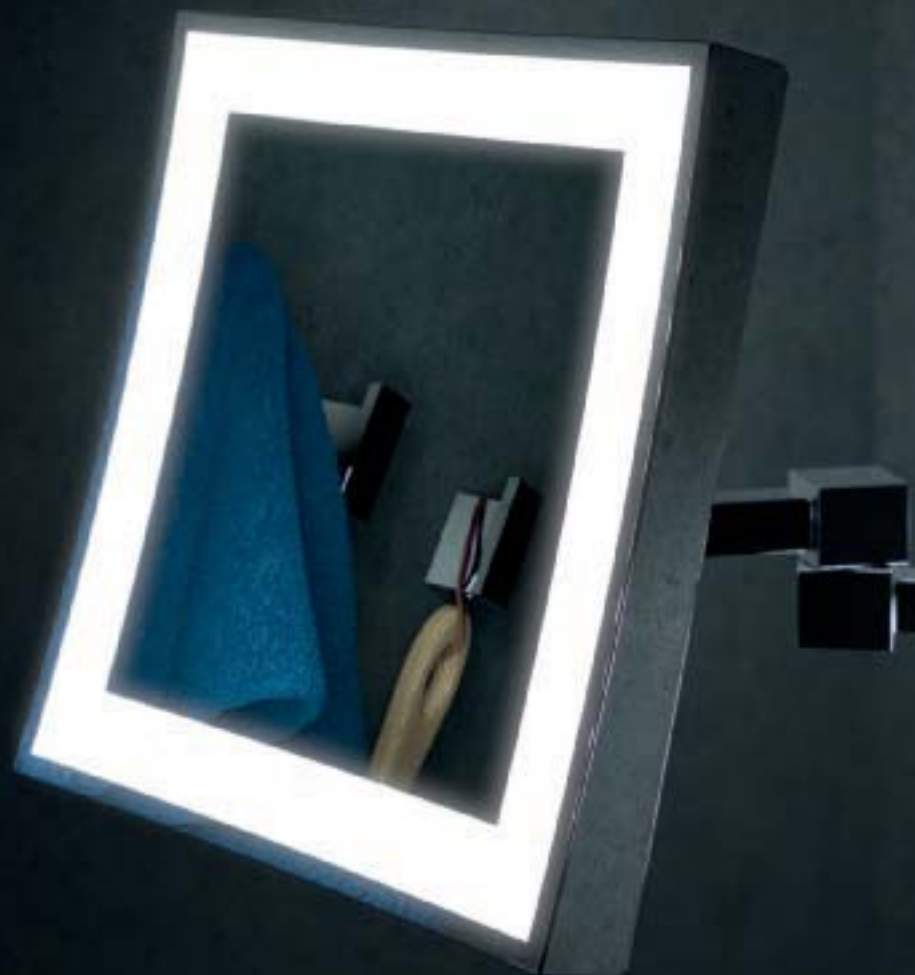

SPIEGEL: EEN PRACHTIGE REFLECTIE VAN DESIGN

Een spiegel is niet alleen functioneel als hulpje bij het scheren of make-up aanbrengen, het geeft ook een ruimtelijk effect aan de badkamer. Bij de Geesa mirror-collectie gaan gebruiksgemak en design hand-in-hand. Onze spiegels zijn vervaardigd uit een combinatie van kwaliteitsglas, duurzaam chroom en optionele led-verlichting. Onze cosmetische spiegels zijn naar keuze drie keer of vijf keer vergrotend, vrijstaand of wandhangend. Hierbij kan worden gekozen voor een één- of tweearmige spiegel in zowel ronde, vierkante en rechthoekige vormen.

A mirror is functional as an aid to shaving and applying make-up, and in addition provides your bathroom with a spatial effect. Ease of use and design go hand-in-hand in the Geesa mirror collection. Our mirrors are made of a combination of high-quality glass, durable chrome and optional LED lighting. Our cosmetic mirrors are available with a three or five times magnifying feature, separate or wall-mounted. You can choose a one-armed or two-armed mirror in round, square and rectangular designs.



TOONE



Mix & Match

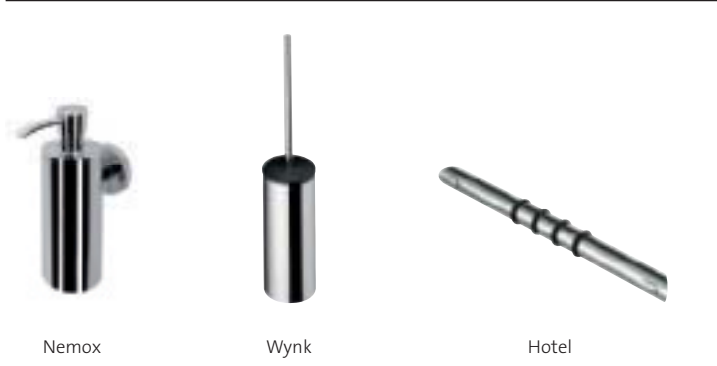



Visit www.geesa.com for detailed information



HOTEL

De Hotel collectie is al een eeuw lang onze basis serie en wordt wereldwijd ingezet in hotels en publieke ruimtes. De collectie kenmerkt zich door functionaliteit.

The Hotel collection has been our basic series for a century and is used in hotels and public spaces all over the world. The collections is characterised by functionality.



LUNA





STANDARD
PUBLIC
AREA



Visit www.geesa.com for detailed information



BASKETS

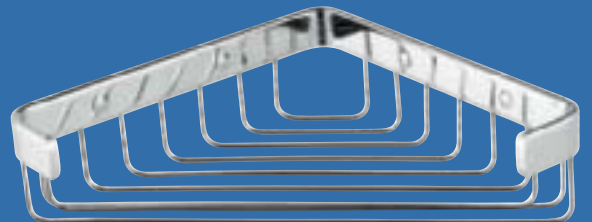
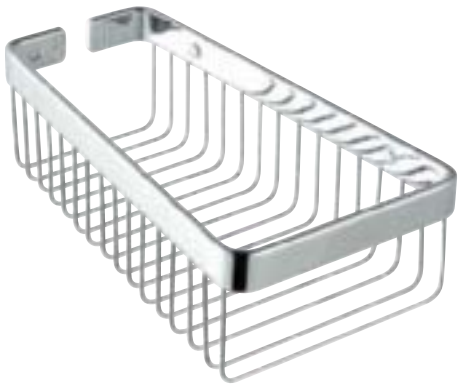

Iedereen kent het wel, de talloze flessen shampoo en douchegel in de badkamer. Nijs zo handig als een basket, ofwel een douche- of badkorf, om de flessen geordend in op te bergen. De basket zorgt ervoor dat de douche of het bad opgeruimd en netjes blijft en heeft zich hiermee onmisbaar gemaakt in elke badkamer.

Rond 1930 zijn wij gestart met de productie van zeepbakjes. In het verlengde daarvan zijn wij baskets gaan produceren. Nog steeds maken wij zo'n 60.000 baskets op jaarbasis, waarvan ongeveer de helft voor consumenten en de andere helft voor projecten geproduceerd wordt. Wij hebben de grootste collectie baskets en worden daarom ook wel de 'basketkoning' genoemd. Wij zijn erin geslaagd om de baskets steeds meer te verfijnen en heeft baskets in allerlei soorten, maten en stijlen. Zo zijn er muurbaskets, hoekbaskets, hangbaskets in zowel moderne als klassieke uitvoeringen.

Everyone is familiar with the sight of all those shampoo and shower gel bottles in the bathroom. This is where a basket comes in handy, to store them all neatly. Baskets ensure that your shower or bathroom stays tidy and organised, and are therefore an essential item in every bathroom.

Around 1930 we started and have continued making baskets. Today, about 60,000 baskets are produced every year, half of which are intended for consumers and the other half for projects. We have the largest collection of baskets and are also referred to as the 'king of baskets'. We have successfully refined them year after year, resulting in baskets of various types, sizes and styles. There are wall baskets, corner baskets and hanging baskets in both modern and classic designs.

Mix & Match



Haiku



Nelio



Tone



Tone Gold

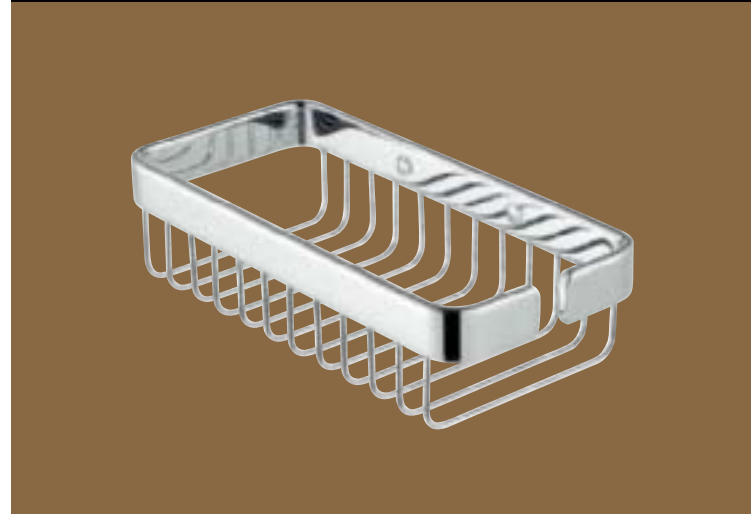



Mix & Match



Nemox



Basket



Mirror Cosmetic





Puur en verrassend als de natuur. De Wynk collectie is een spannende serie met geraffineerde, haast organische vormen. Strakke lijnen worden afgewisseld met subtiele curves die de serie een tijdloze elegantie verlenen. Wynk is een breed opgezette collectie die naadloos past in een veelvoud van badkamerinterieurs.

Materiaal

Zamac verchromd
RVS verchromd.

Refreshing like nature, the Wynk collection is an exciting series consisting of refined and almost organic shapes. Austere lines alternate with subtle curves that provide a timeless elegance. Wynk is an extensive collection that works beautifully in numerous bathroom interiors.

Material

Chromeplated zamac,
chromeplated stainless steel.

Visit www.geesa.com for detailed information

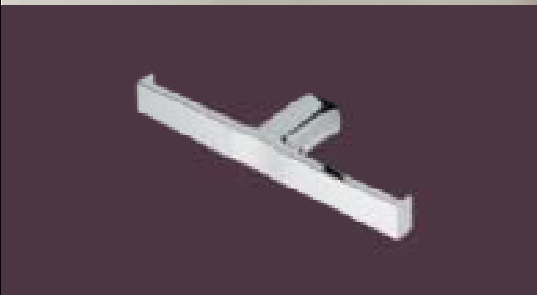

Door de sterke combinatie van zuiver geometrische vormen, is Neliö een smaakvolle, stoere serie. In het Fins betekent Neliö 'vierkant' en dat is dan ook waar deze serie grotendeels op gebaseerd is: een aantrekkelijk kubistisch lijnenspel is te zien in de wandbevestiging. De serie kenmerkt zich door een robuust vierkant muurblok, welke aangevuld wordt met ronde vormen binnen het accessoire. Dit zorgt voor een spannend samenspel. Neliö is van glanzend chroom en straalt in elke moderne badkamer allure uit.

The strong combination of pure, geometric shapes make Neliö an elegant and sturdy series. In Finnish, Neliö means 'square', and this is exactly what this series is based on: an appealing cubic line pattern which is also seen in the wall mounting. The series is characterised by a robust square wall block supplemented with round shapes in the accessory, resulting in an exciting interplay. Neliö is made from shiny chrome and radiates allure in every modern bathroom.



NELIÖ



Visit www.geesa.com for detailed information

Mix & Match



Nemox



Mirror cosmetic



Hotel



Mirror cosmetic



Nexx





Visit www.geesa.com for detailed information



NEMOX
STAINLESS
STEEL



BLOG



NEXX

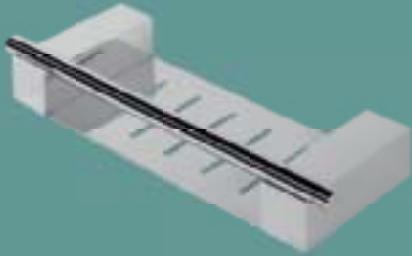

Visit www.geesa.com for detailed information





Visit www.geesa.com for detailed information

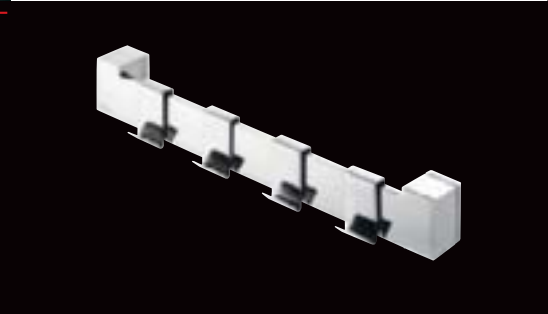

Magnets attached to
various articles ensure
these items stay where they are.



Magnetic Attraction

Poëzie voor de badkamer, met die ondertitel lanceert Geesa een collectie accessoires ontworpen door één van Nederlands beroemdste designers Marcel Wanders. Deze collectie, vernoemd naar de Japanse dichtvorm Haiku, laat verrassende combinaties toe van verschillende materialen als chroom, keramiek en wengé hout. Diverse artikelen zijn voorzien van een magneet waardoor ze onverstoort blijven staan.

Under the title of Poetry for the Bathroom, Geesa has launched a collection of accessories created by one of the Netherlands' most celebrated designers, Marcel Wanders. The Haiku collection, named after the Japanese style of poetry, brings together surprising combinations of various materials, such as chrome, ceramics and wengé wood. Many items come with a magnet, so they cannot be easily moved or knocked over.

Mix & Match



Modern art



Modern art



Modern art

Materiaal
verchroomd 304
RVS, verchroomd
zamac, wengé
houtfineer,
porselein.
Sommige
producten zijn
uitgerust met
magneten.

Material
chromplated 304
stainless steel,
chromeplated
zamac, wengé
wood veneer,
porcelain.
Some products
are fitted with
magnets.

Haiku BY Marcel Wanders







Garantietermijnen

Conform onze Algemene Verkoop-en Leveringsvoorwaarden.

| | |
|------------------------|--|
| Alle collecties; | |
| chromen en constructie | 12 jaar |
| Keramiek | 12 jaar |
| Houtfineer | 5 jaar |
| RVS | 5 jaar |
| Zeepdispensers | 2 jaar |
| Mirror: | Cosmetic 2 jaar (op verzilveringslaag) |
| Handdrogers | 2 jaar |
| Haardrogers | 2 jaar |
| Weegschalen | 2 jaar |
| Emmerrooster | 2 jaar (op constructie) |

Guarantee terms

In accordance with our general sales and delivery terms.

| | |
|-------------------------|-----------------------|
| All collections, | |
| chrome and construction | 12 year |
| Ceramics | 12 year |
| Wood veneer | 5 year |
| Stainless steel | 5 year |
| Soap dispensers | 2 year |
| Mirror: Cosmetic | 2 year (silver layer) |
| Hand dryers | 2 year |
| Hair dryers | 2 year |
| Body scale | 2 year |
| Bucket grates | 2 year (construction) |

Onderhoudstips

U kunt onze producten het beste reinigen met een zachte, vochtige doek en een normale huishoudreiniger. Gebruik geen agressieve reinigingsmiddelen. Roestvaststaal kunt u het beste reinigen met een zogenaamde microvezel doek met glasreiniger of een speciaal reinigingsmiddel voor roestvast staal. Geen producten met chloor- of zoutzuuroplossingen gebruiken. Plastic onderdelen reinigen met regulier schoonmaakmiddel.

Maintenance tips

The best way to clean our products is with a soft, damp cloth. Do not use abrasive or aggressive cleaners. It is best to clean the stainless steel cover with a so-called microfibre cloth with a glass cleaner or a special stainless steel cleaner. Do not use products which contain chlorine or hydrochloric acid solutions. Clean plastic parts with normal household cleaner.



Referenties

Onze passie voor kwaliteit heeft geresulteerd in een leidende, internationale positie in de luxe hotels en de scheepvaart. In meer dan 1100 hotels en cruiseschepen wereldwijd zijn inmiddels onze producten geïnstalleerd. Belangrijke ketens als Holiday Inn, Intercontinental en Radisson Blu (SAS) hebben Geesa zelfs verkozen tot 'preferred supplier'. Zo zijn de onder andere de "Oasis of the Seas" en de "Celebrity Solstice", met elk 4000 cabines aan boord de grootste cruise schepen ter wereld, compleet uitgerust met Geesa accessoires.

References

Our passion for quality has resulted in an authoritative international position in deluxe hotels and shipping. Today, our products have been installed in over 1100 hotels and cruiseships worldwide. Important chains such as the Holiday Inn, Intercontinental and Radisson Blu (SAS) have proclaimed Geesa as a preferred supplier. Ships such as 'Oasis of the Seas' and the 'Celebrity Solstice', each with 4000 cabins on board and thus the largest cruise ships in the world, have been furnished entirely with Geesa accessories.



Geesa b.v.
Vanadiumweg 2
3812 PZ Amersfoort
The Netherlands

Tel: +31 (0)33-4633214
Fax: +31 (0)33-4637186
geesa@geesa.nl
www.geesa.com

